

# PROGRAMA PARA EL ENTRENAMIENTO DEL PROCESO COGNITIVO NIVEL INICIAL 5 AÑOS

## INTEGRANTES:

- CARDENAS MEDINA GUILIANA
- MONTERREY CARPIO ROSARIO
- RAMIREZ ROQUE MARIA DE FATIMA

# PRESENTACION

ESTE TRABAJO SE HA REALIZADO CON EL FIN DE DAR UN APOORTE A TODOS LOS DOCENTES DEL NIVEL INICIAL PARA QUE ASI TENGAN FICHAS PARA EL TRABAJO CON LOS NIÑOS EN LAS DISTINTAS AREAS COMO SON:

- LATERALIDAD
- PROCESOS DE PERCEPCION
- PENSAMIENTO
- LENGUAE
- ORIENTACION
- MEMORIA
- ATENCION

ESPERANDO QUE LE SEA DE GRAN AYUDA YA QUE EN LA ACTUALIDAD NO HAY MUCHOS DOCUMENTOS DE DONDE SE PUEDAN SACAR FICHAS PARA EL TRABAJO DIARIO CON NUESTROS NIÑOS.

## INDICE

1. PRESENTACION
2. INDICE
3. LATERALIDAD
4. FICHAS
5. PROCESOS DE PERCEPCION

6. FICHAS
7. PENSAMIENTO
8. FICHAS
9. LENGUAJE
10. FICHAS
11. ORIENTACION
12. FICHAS
13. MEMORIA
14. FICHAS
15. ATENCION
16. FICHAS

## LATERALIDAD

OJO	DERECHO	IZQUIERDO
1. MIRA POR UN TUVO		
2. VISUALIZA IMÁGENES TAPANDOSE UN OJO		
3. SIGUE SECUENCIAS DE IMÁGENES CON UN OJO		
4. VISUALIZA DIFERENCIAS ENTRE IMÁGENES TAPANDOSE UN OJO		
5. RECONOCE COLORES		

TAPANDO UN  
OJO

6. RECONOCE  
FORMAS  
TAPANDO UN  
OJO

## **MANO**

1. RECORTA
2. DESGLOSA
3. RASGA
4. COLOREA
5. SIGUE LOS  
TRAZOS
6. EMBOLILLA
7. ESCRIBE
8. ENVUELVE LANA

## **PIE**

1. Patea la pelota
2. Marcha
3. SALTA CON 1 PIE
4. CAMINA
5. CORRE
6. PEDALEAR
7. REPTAR
8. CAMINA EN ZIG-  
ZAG

## **OIDO**

1. REPITE UNA  
CANCION
2. SE DA CUENTA  
CUANDO LA  
MUSICA SUENA  
MAL
3. RECUERDA  
MELODIAS
4. ES SENSIBLE A  
RUIDOS  
AMBIENTALES
5. RECONOCE UNA  
CANCION SOLO  
CON TARAREO

# LATERALIDAD

## FICHAS DE LATERALIDAD

- *Recorta con tijeras por las líneas entrecortadas hasta llegar al punto.*

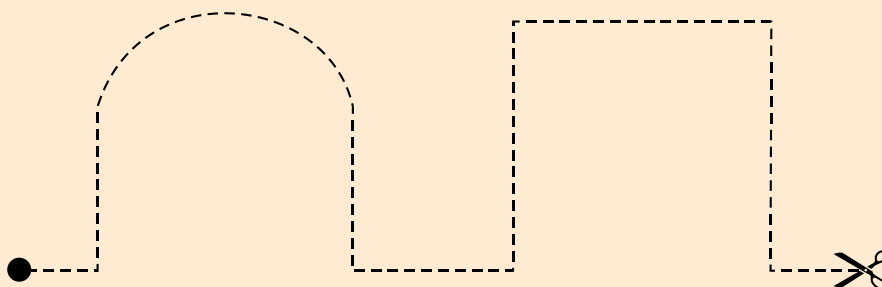
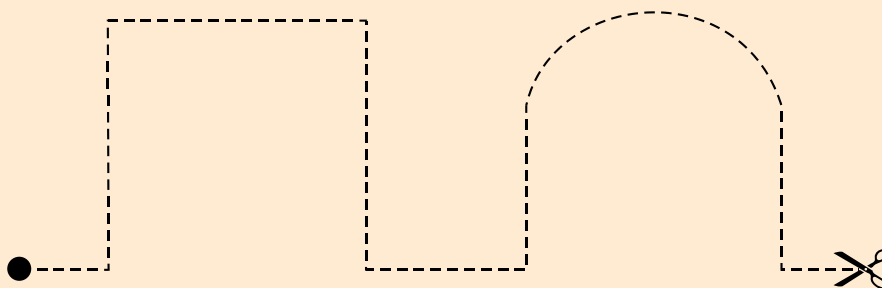
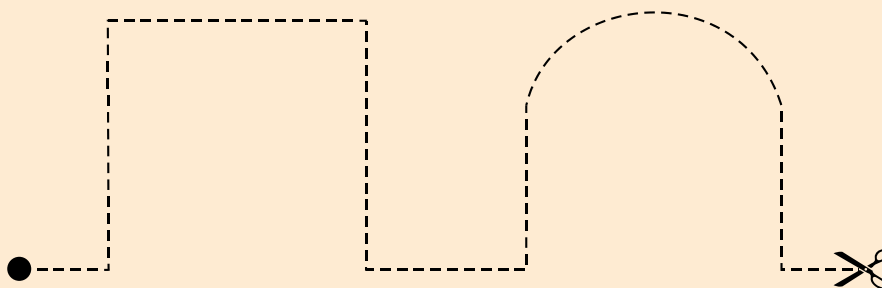



## IZQUIERDA – DERECHA

- *Reconoce tus lados derecho e izquierdo*

- *Colorea el lado derecho de rojo y punza el izquierdo*

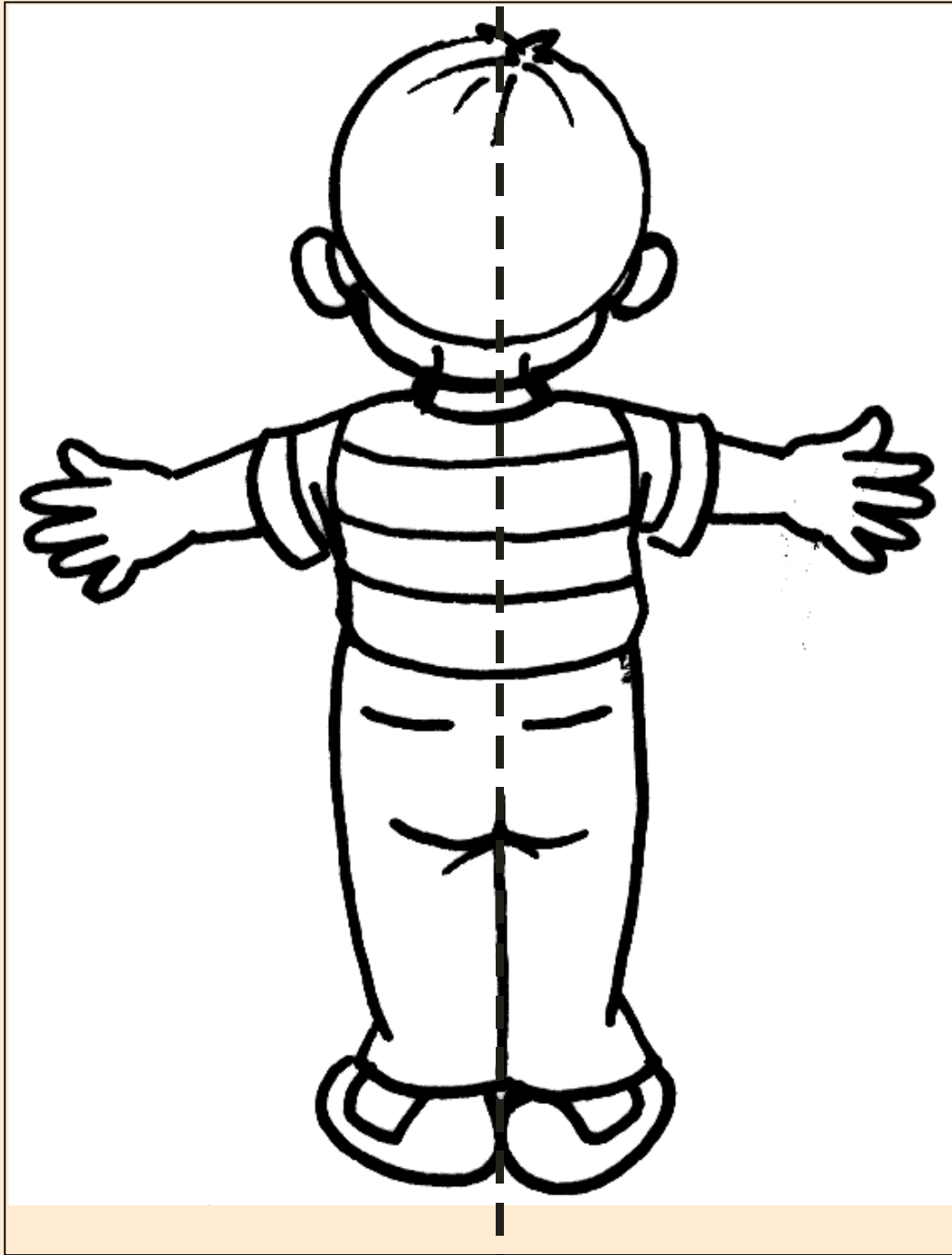

**LOS OSOS BAILARINES**



- ¿Hacia dónde van? Marca X los osos que van a la izquierda ó O si van a la derecha según corresponde en cada oso.

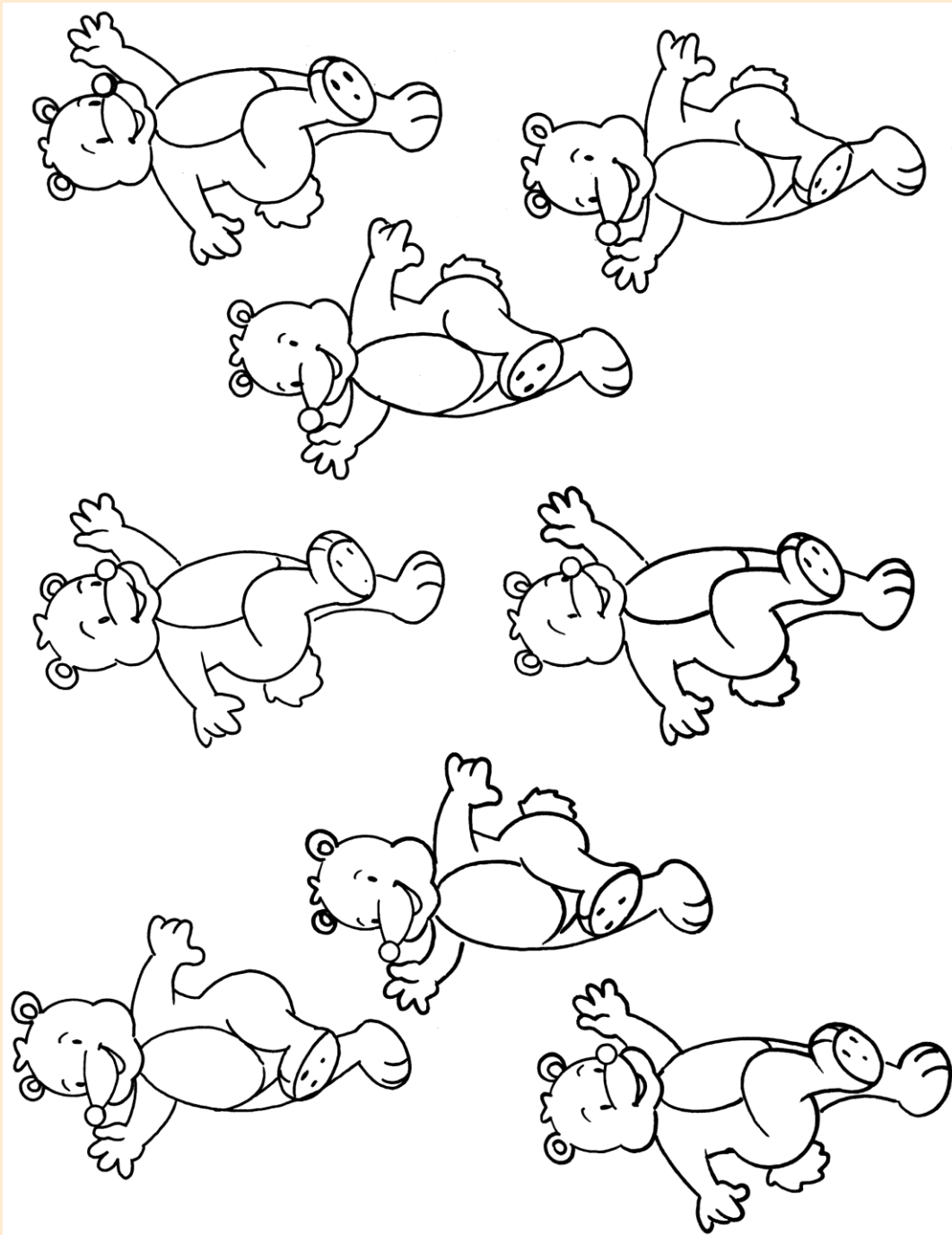
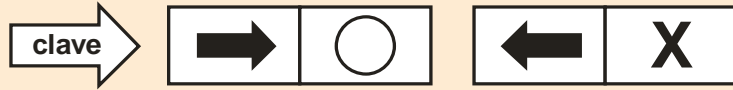

- *Pinta de color rojo: las huellas de los pies y manos derechos, azul las huellas de los pies y manos izquierdos.*



## LATERALIDAD CRUZADA

- Recorta por las líneas entrecortadas las fichas donde figuran los animales, ubica y pega en la cuadrícula según la ubicación que se indica.

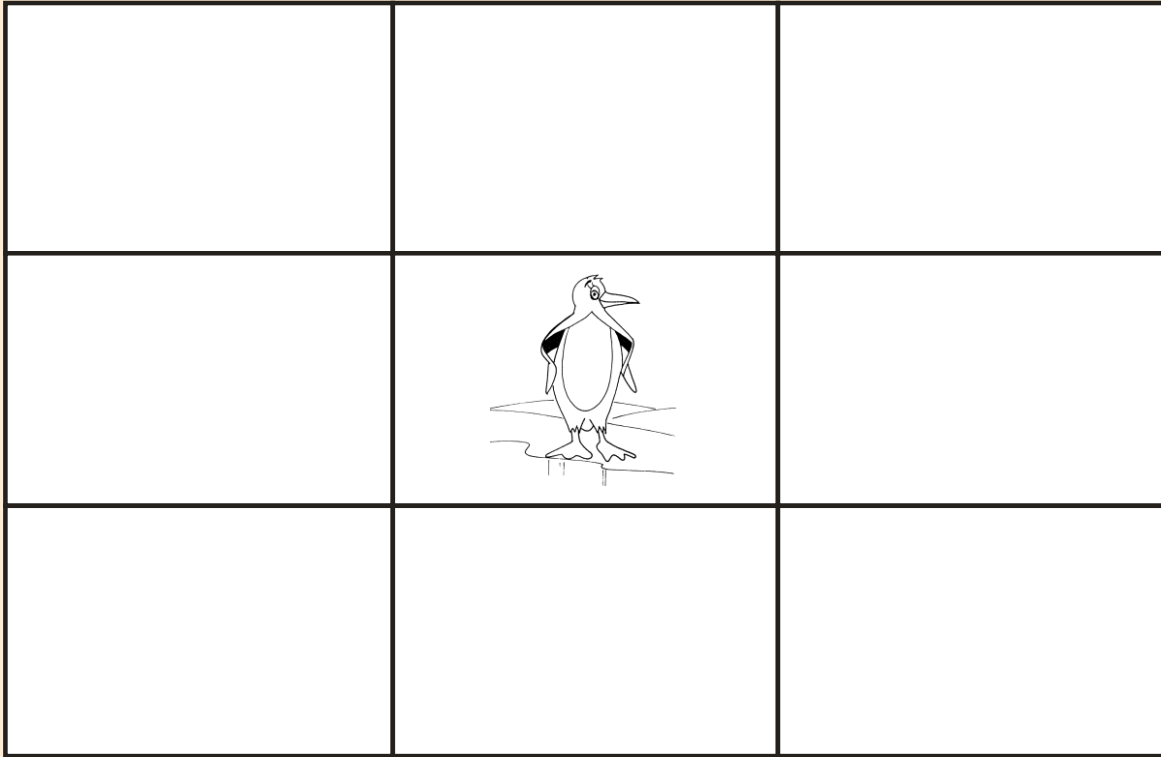

a la derecha del



arriba del



abajo del



a la derecha del



a la izquierda del

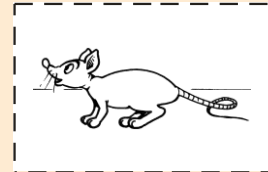
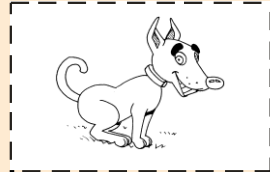
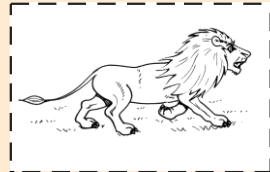

## UBICACIÓN ESPACIAL

- En cada ejercicio colorea la respuesta  
¿Qué juguete está arriba, a la derecha?

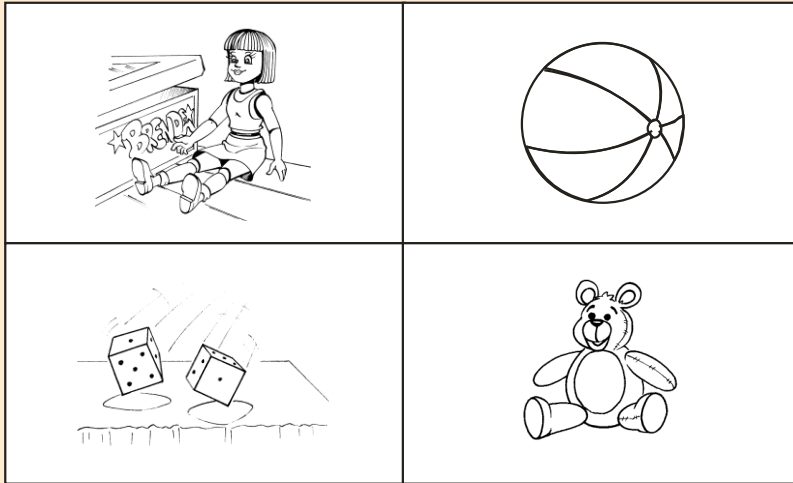

¿Qué útil escolar está abajo, a la izquierda?

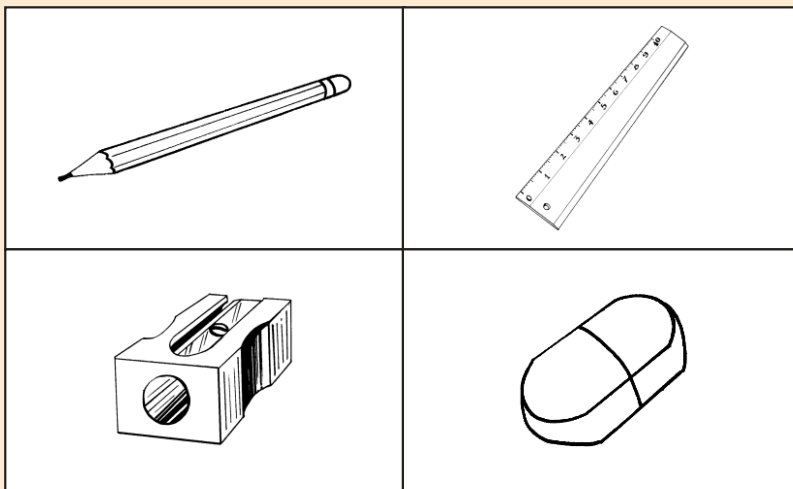

¿Qué útil de aseo está entre el jabón y el caño?

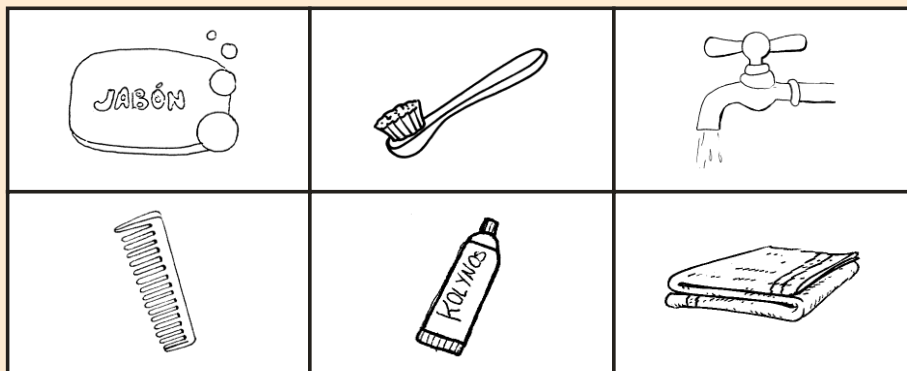

- Colorea de rojo los objetos que van hacia la DERECHA y de azul los que van a la IZQUIERDA.

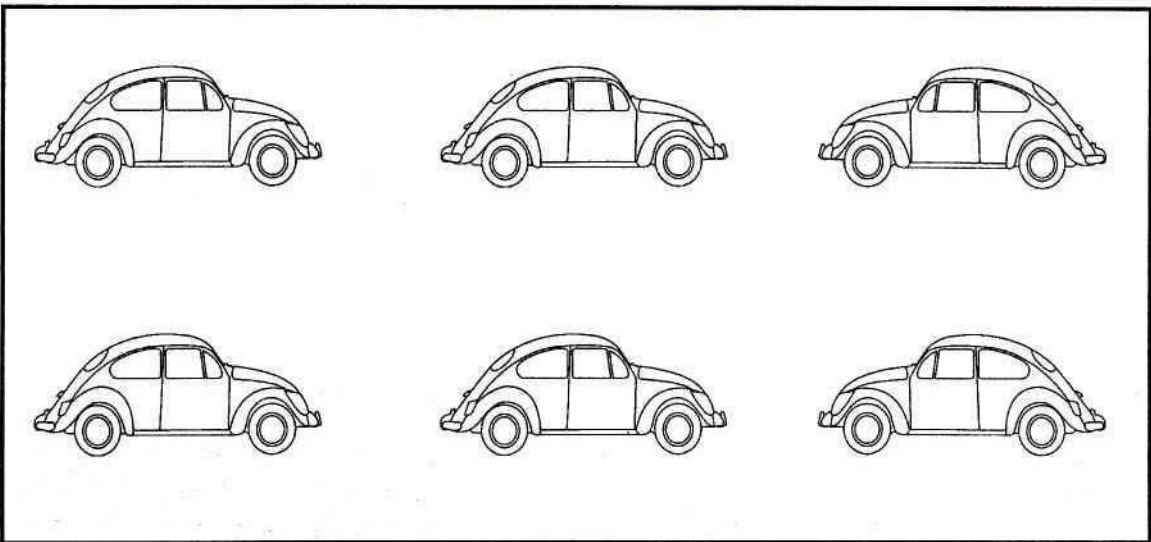
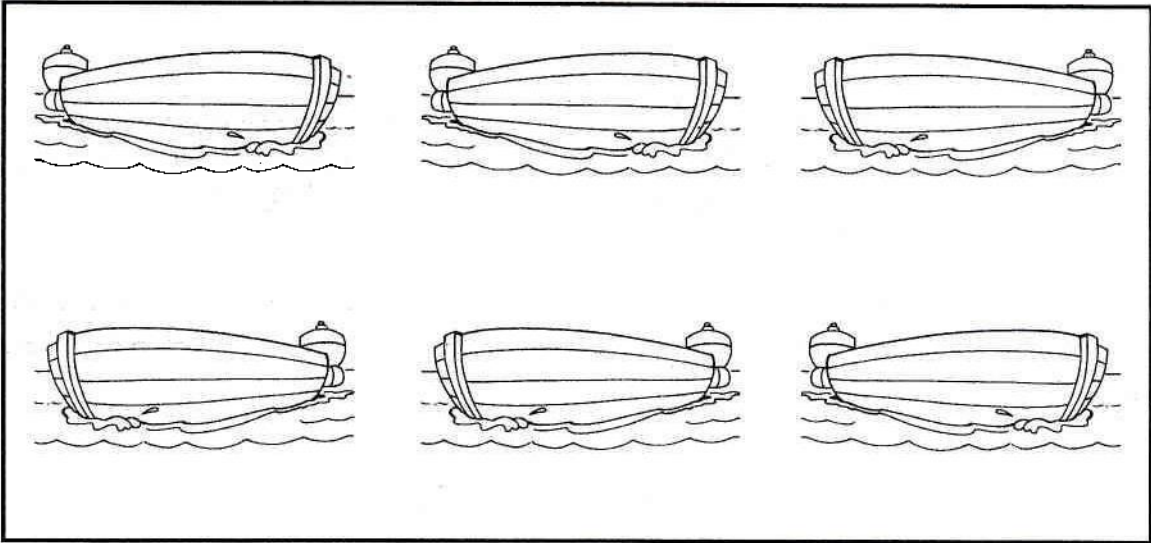
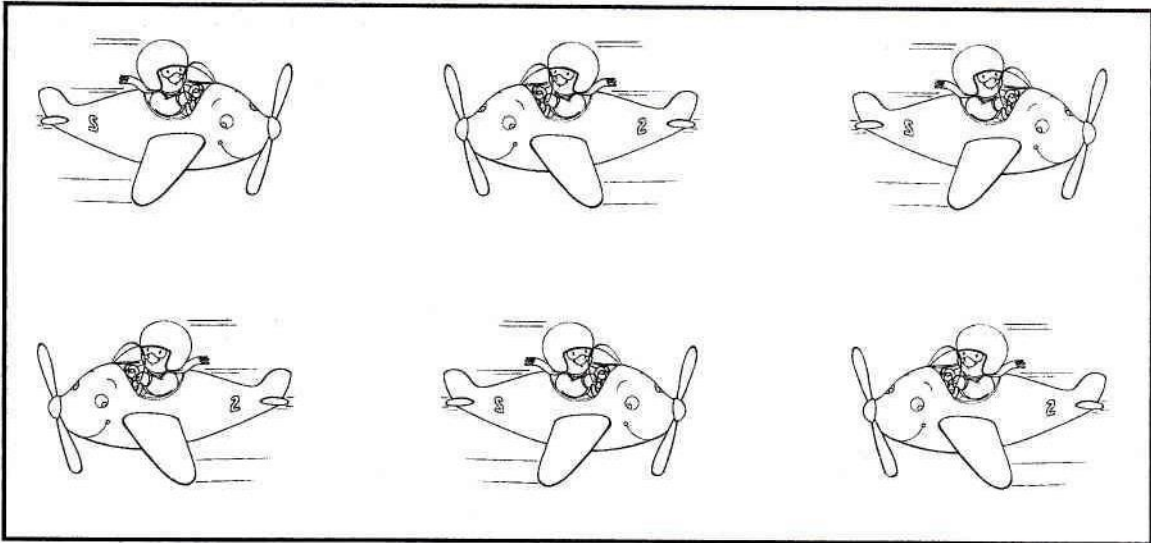

# PROCESOS DE PERCEPCION

## PERCEPCIÓN VISUAL

- Encuentro la figura de la misma forma y de tamaño más grande que la del recuadro, la coloreo.

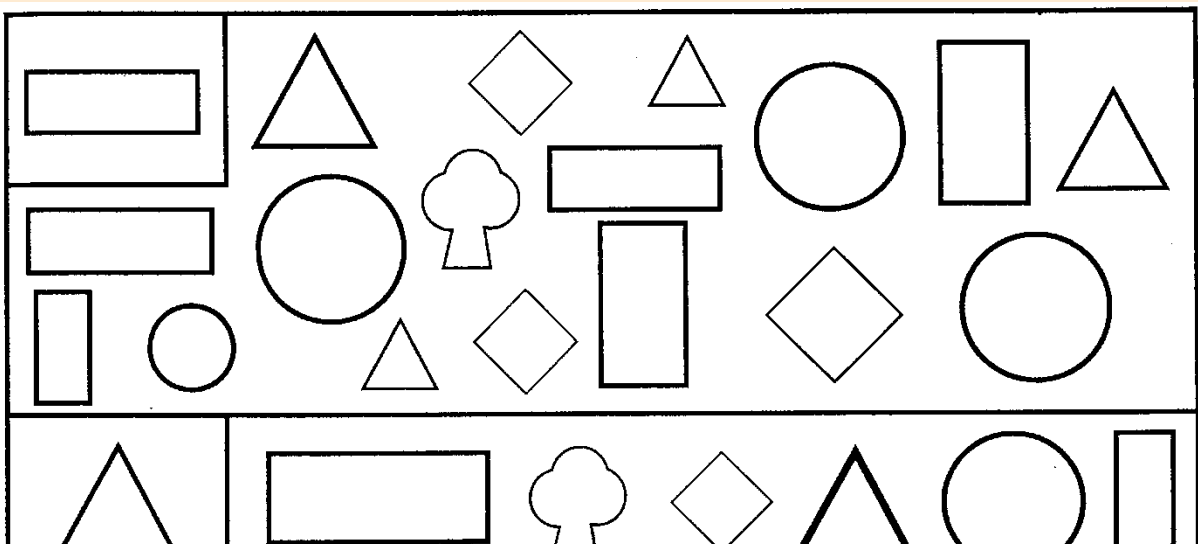

## SOMBRAS

- *Uno con una línea las figuras con las sombras que les corresponden.*

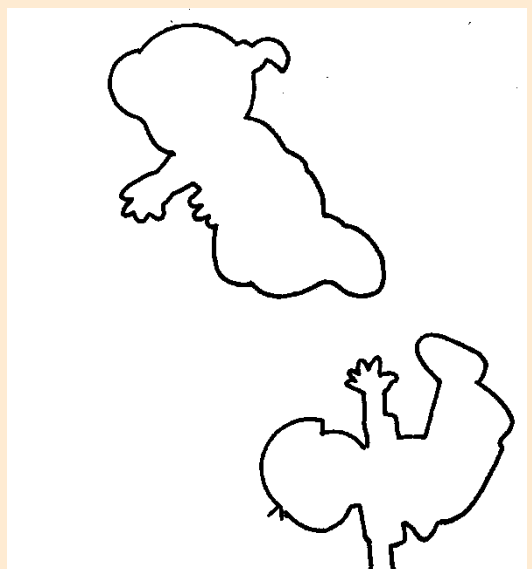

## FIGURAS ESCONDIDAS

- *Busco y pinto a los niños que no tienen anteojos.*





## Percepción visual

- Busca en el recuadro y encierra las letras que forman cada palabra y enciérralas.

PLANCHA



P	H	N	O
U	L	S	A
C	E	A	V

PASTILLAS



I	P	S	L
A	L	B	T
U	E	S	A

TIJERAS

CUCHILLO

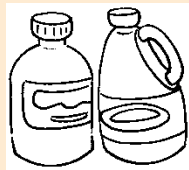
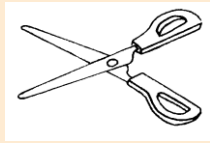

## PERCEPCIÓN VISUAL

- Pinta todos los casilleros donde encuentres la palabra "pato"

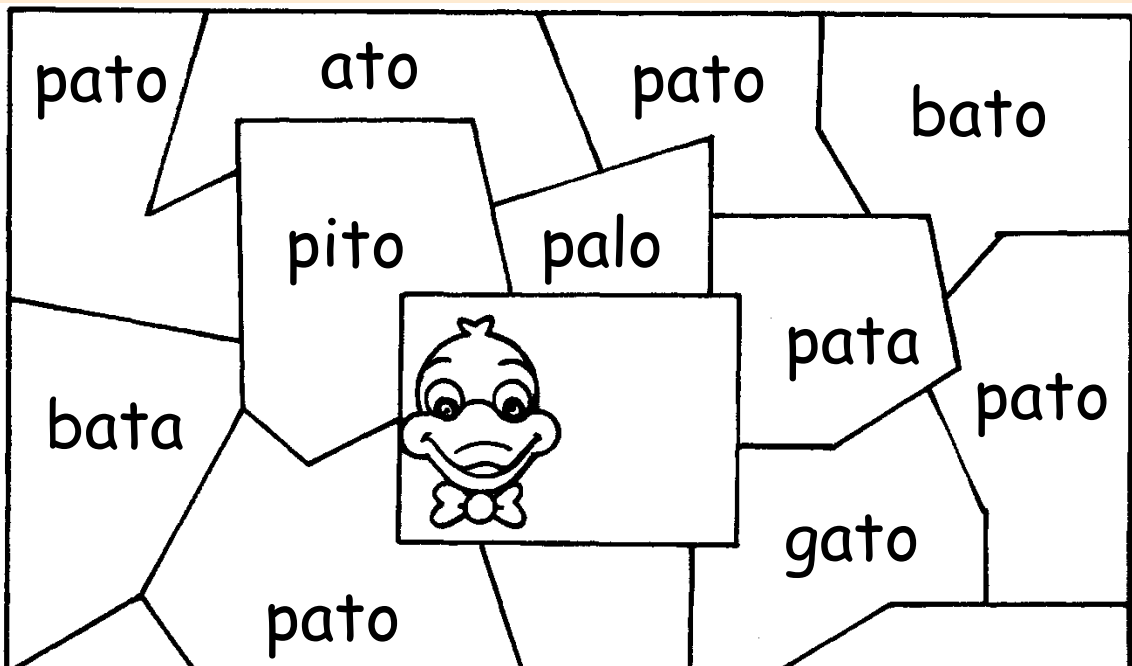

# paso

- Une con líneas de diferentes colores los dibujos con su rompecabezas

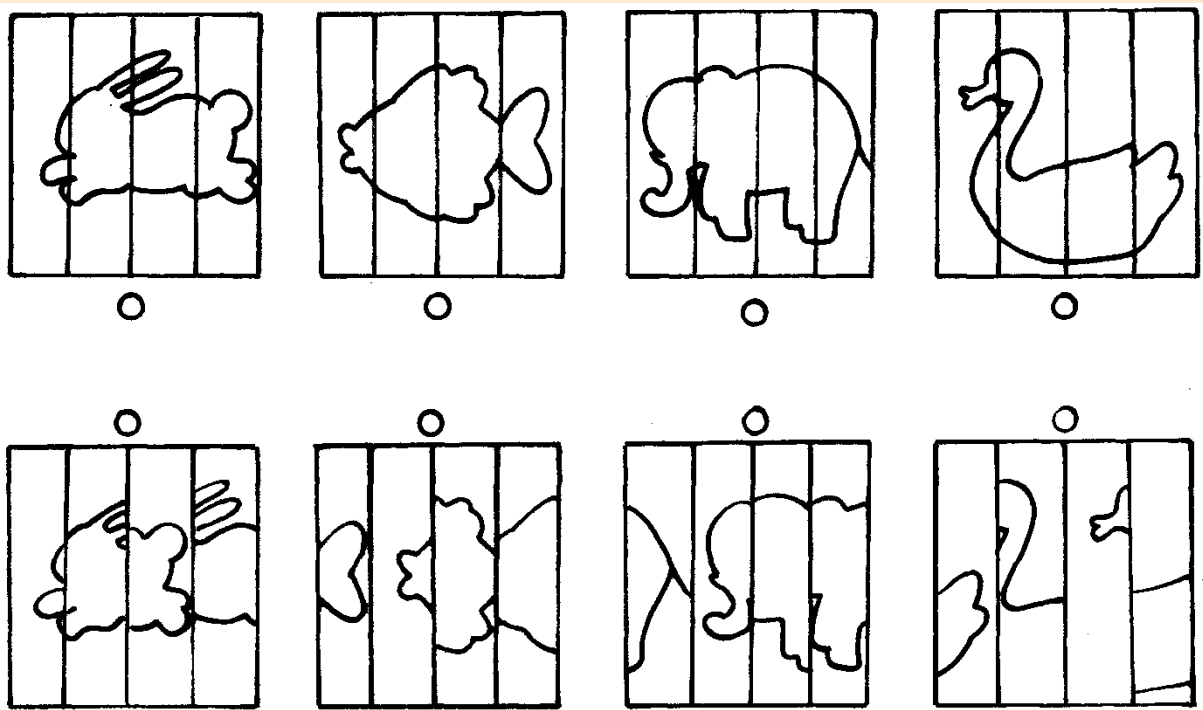



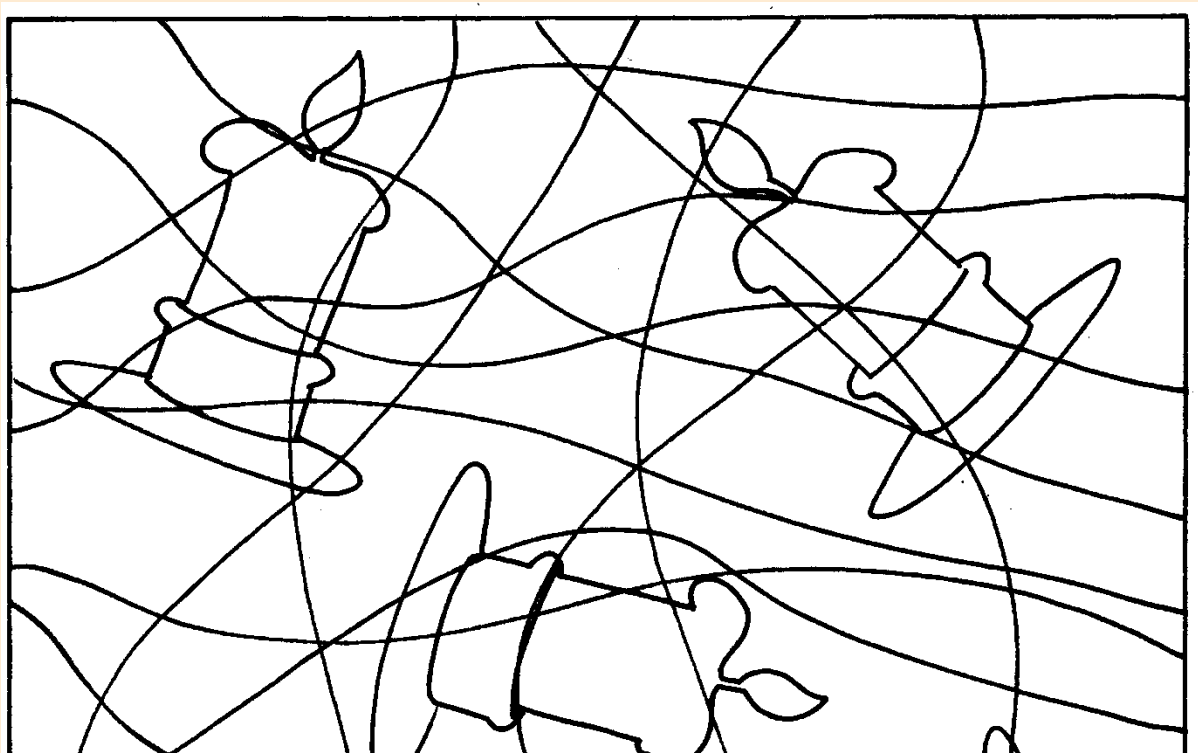



- Encuentra y repásalas con plumón.

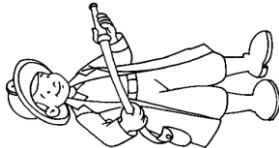
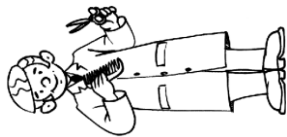

## **TRABAJADORES DE LA COMUNIDAD – ANÁLISIS Y SINTESIS VISUAL**

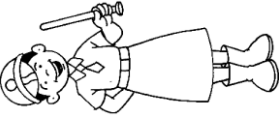
- *Encierra la palabra que resulta al juntar las letras*

		
		
		
<p>o m b r o b e o</p>	<p>s e c r e t a i a r</p>	<p>a r d i j n e r o</p>

**DISCRIMINACIÓN VISUAL**

- Colorea los recuadros que contengan las letras que forman los nombres de los trabajadores de la comunidad.

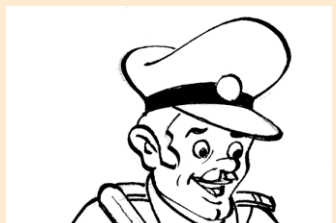



doctor

d	t	o	f	r
u	c	b	o	s

policía

b	s	o	i	í
c	p	d	l	a



pintor

p	n	u	t	r
e	o	i	s	c



albañil

e	d	a	a	i
l	l	ñ	b	o

**FIGURAS INCOMPLETAS**

• *Observa y completa las figuras según el modelo*

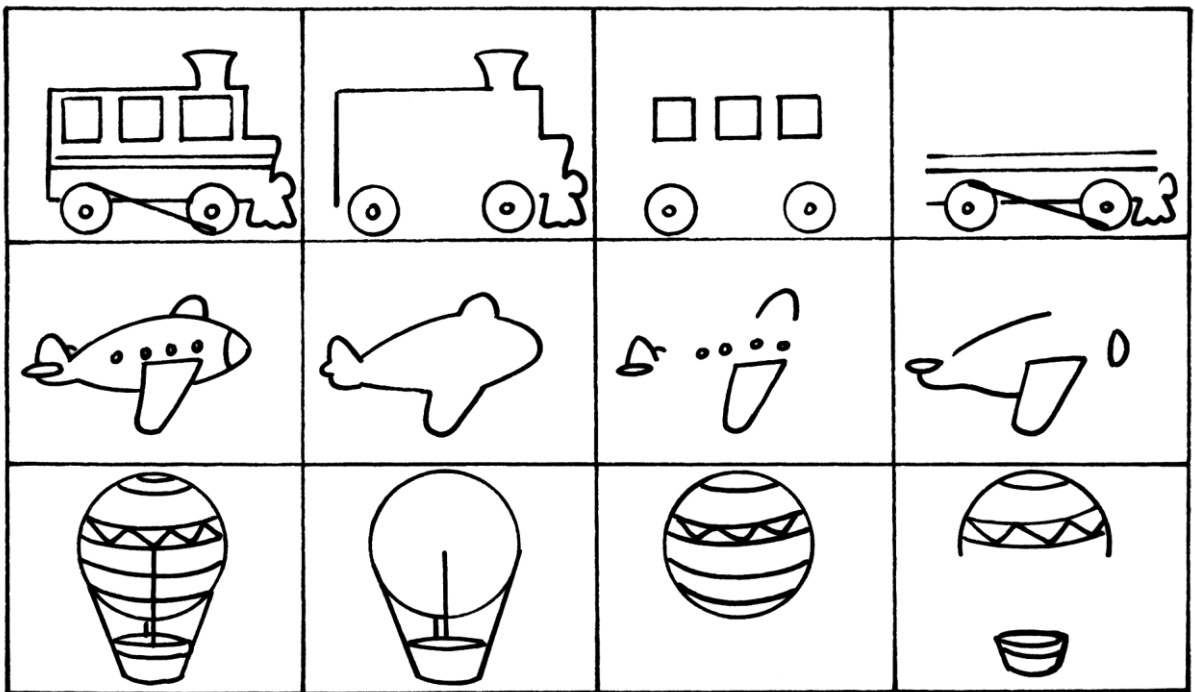
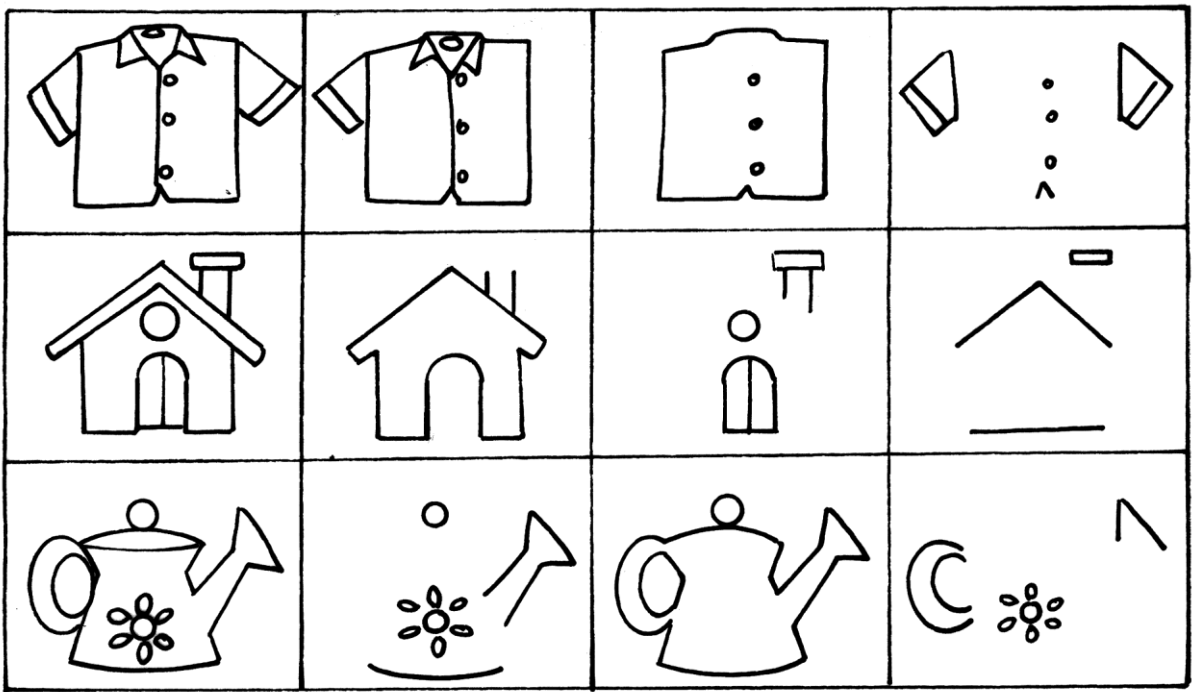

## ¿Cuál es el diferente?

- En cada fila observa e identifica el diferente y enciérralo.

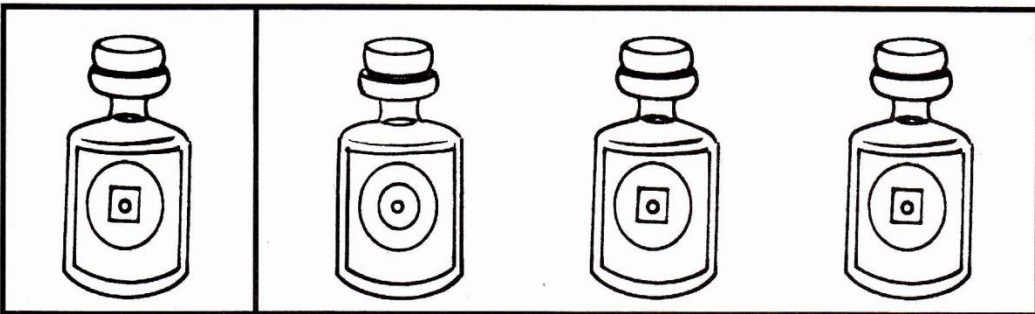
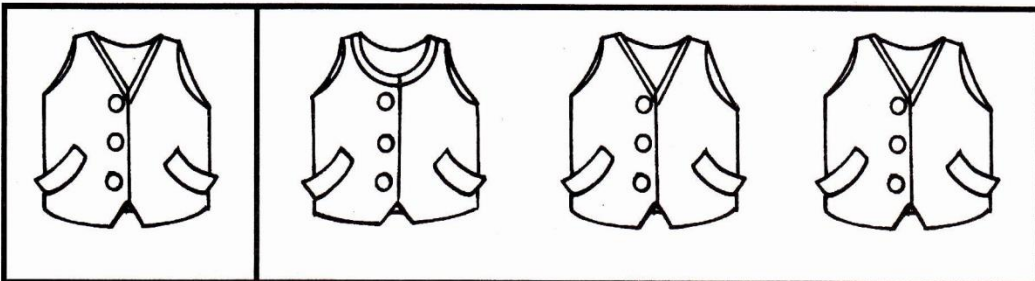
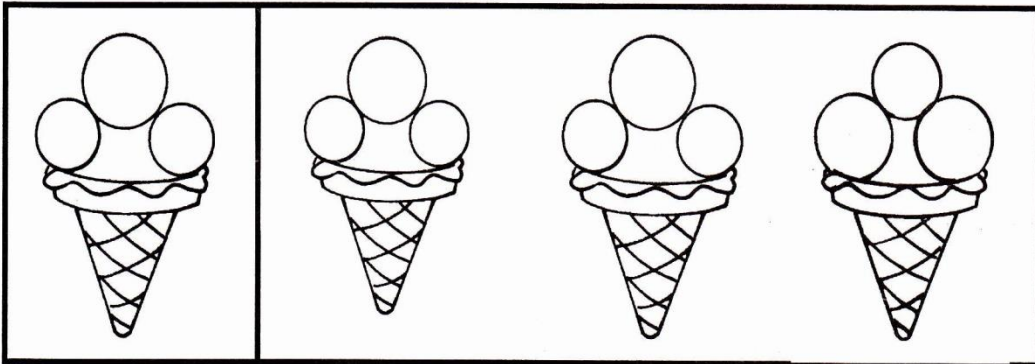
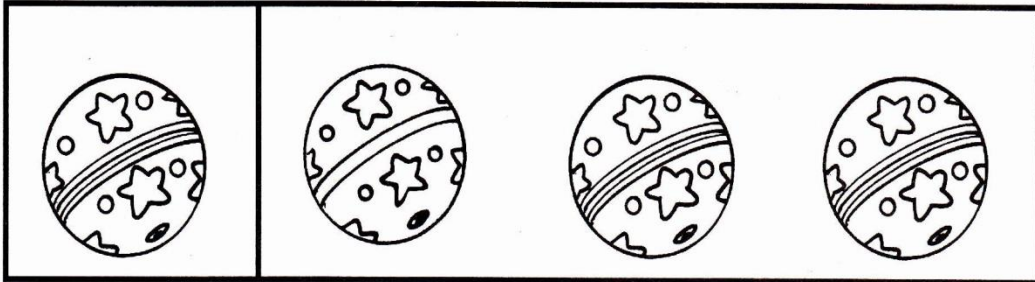



# PERCEPCIÓN AUDITIVA

- Realiza los sonidos de acuerdo al código y sigue la secuencia auditiva.

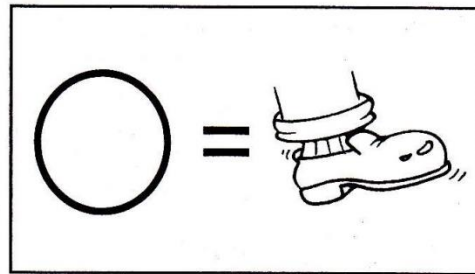
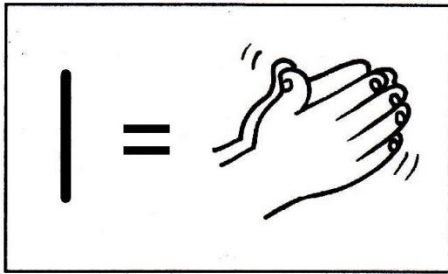

---

| | ○ | | ○ | | ○ | | ○ | |

---

||| ○○ ||| ○○ ||| ○○

---

|○○○ |○○○ |○○○ |○○○

# SEMEJANZAS

- Encuentro la figura igual al modelo y la encierro con crayola azul.

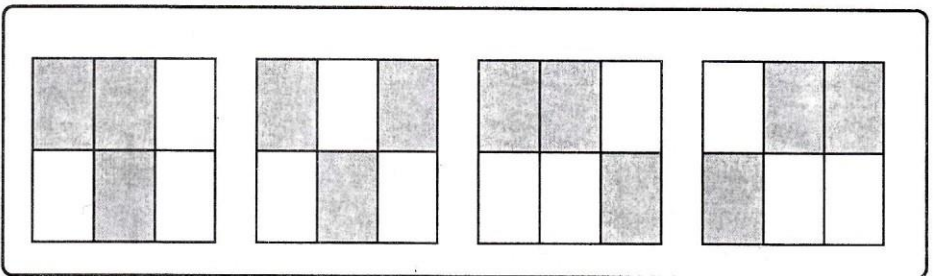
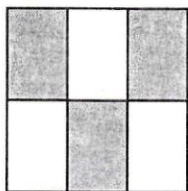
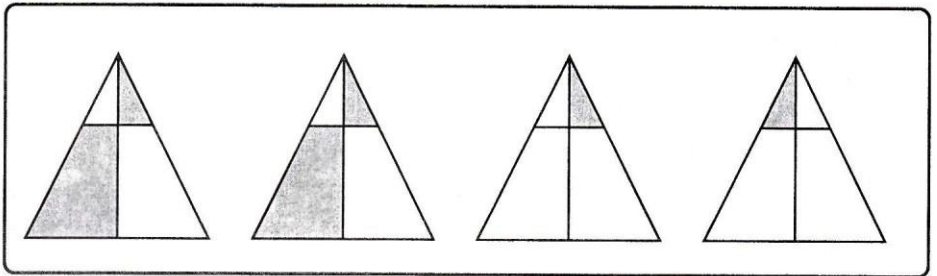
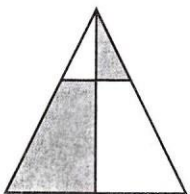
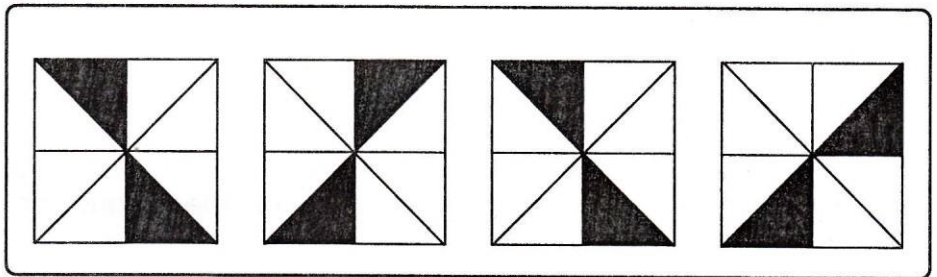
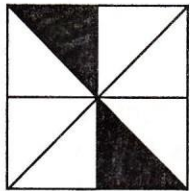
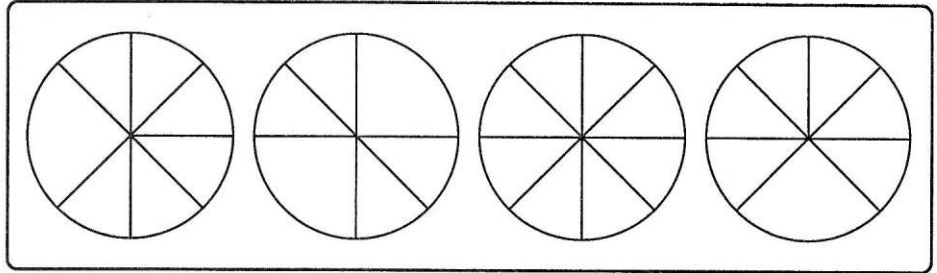
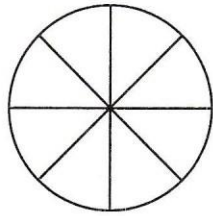

## TACHA LOS IGUALES

- Tacha con una cruz los que son iguales al primero de su fila, como en el ejemplo.

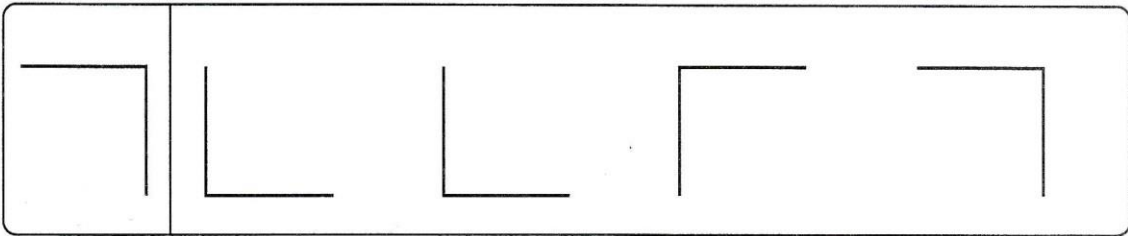
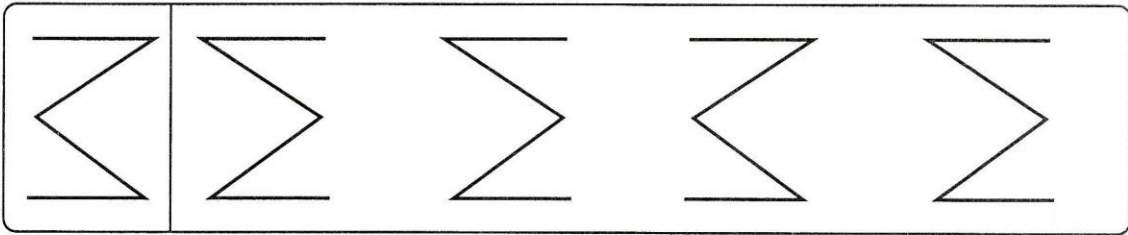
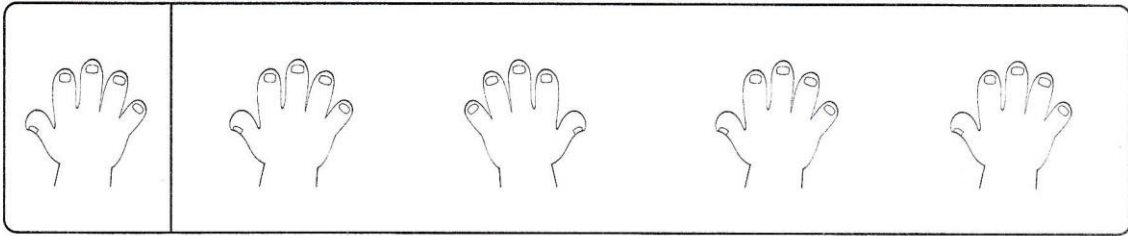
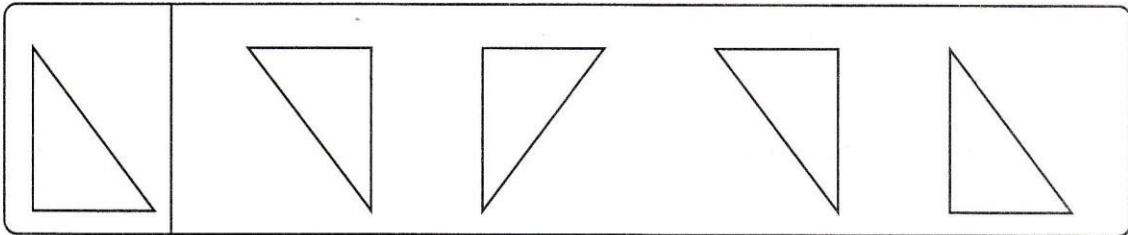
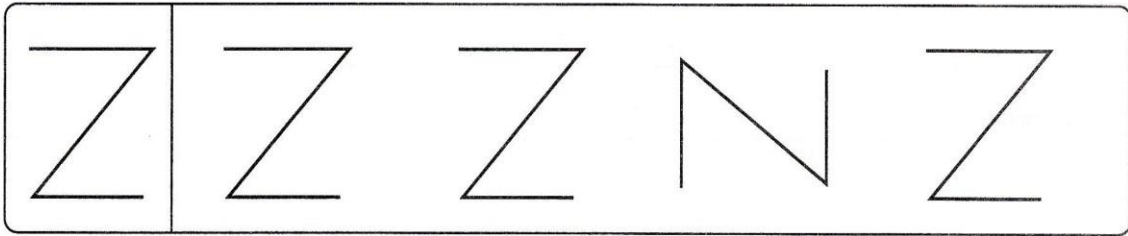
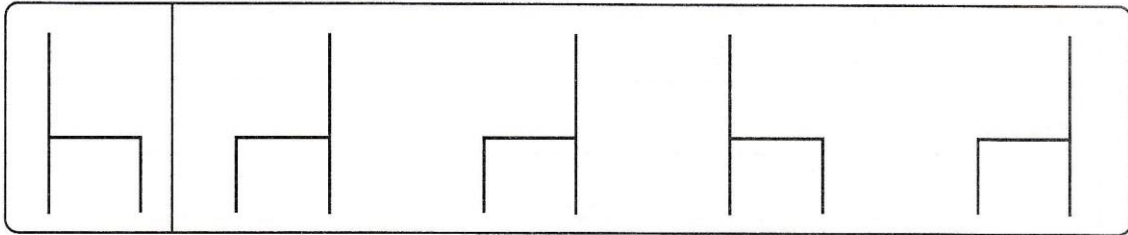

• Pinta de acuerdo a los códigos de color.

d = Amarillo

c = Verde

b = Negro

a = Celeste

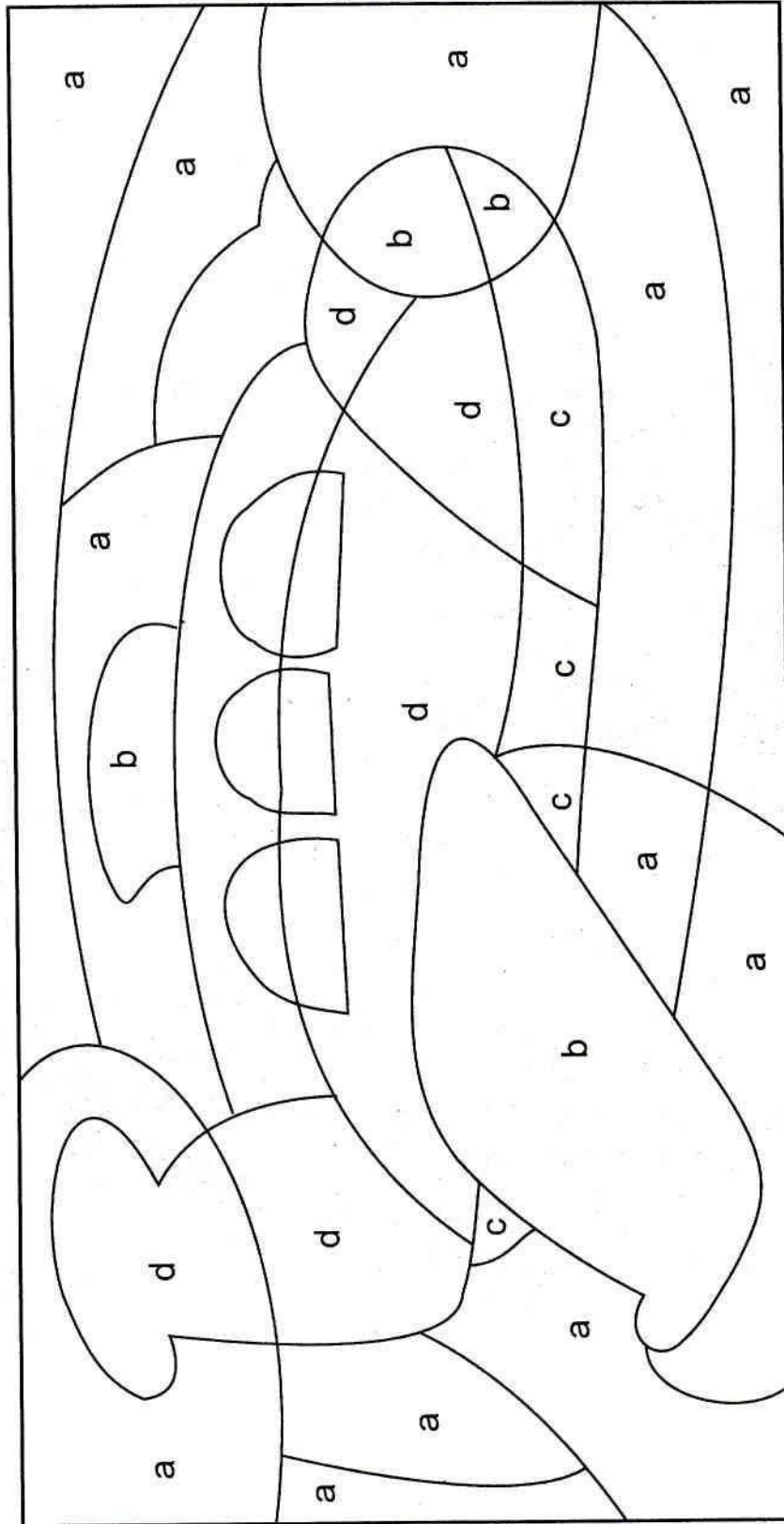

# PENSAMIENTO

## **El camino de las figuras**

- *Observa la secuencia de figuras de la parte de arriba ¿son iguales? ¿qué orden siguen?*

- *Une relacionando de acuerdo al orden del modelo.*

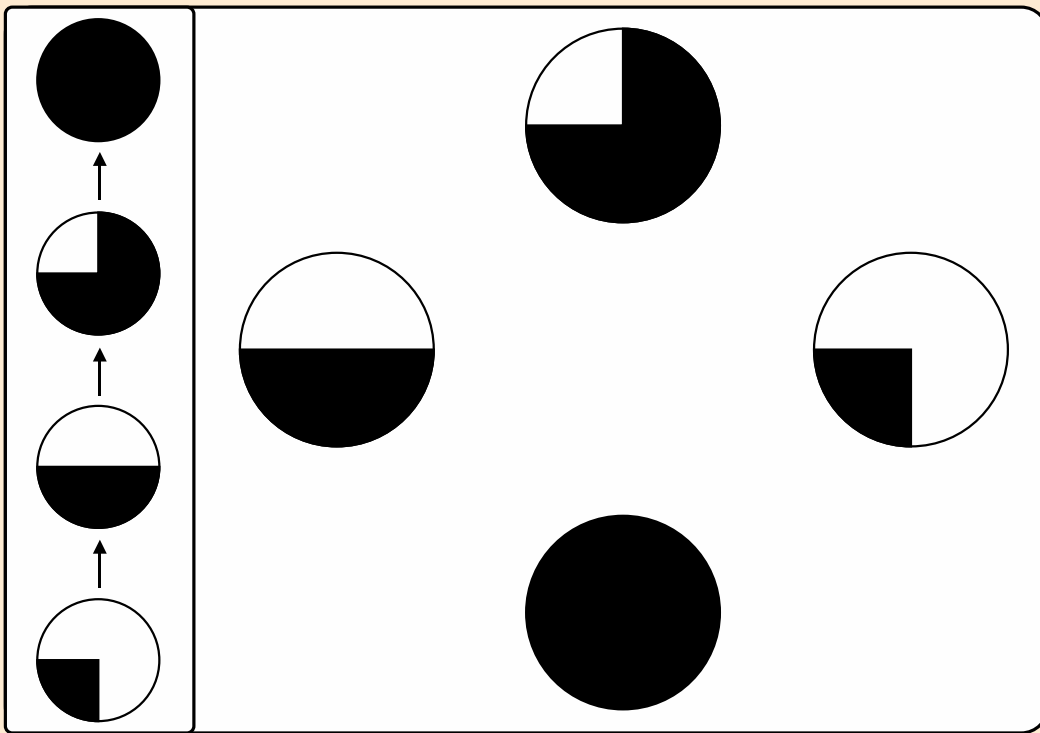
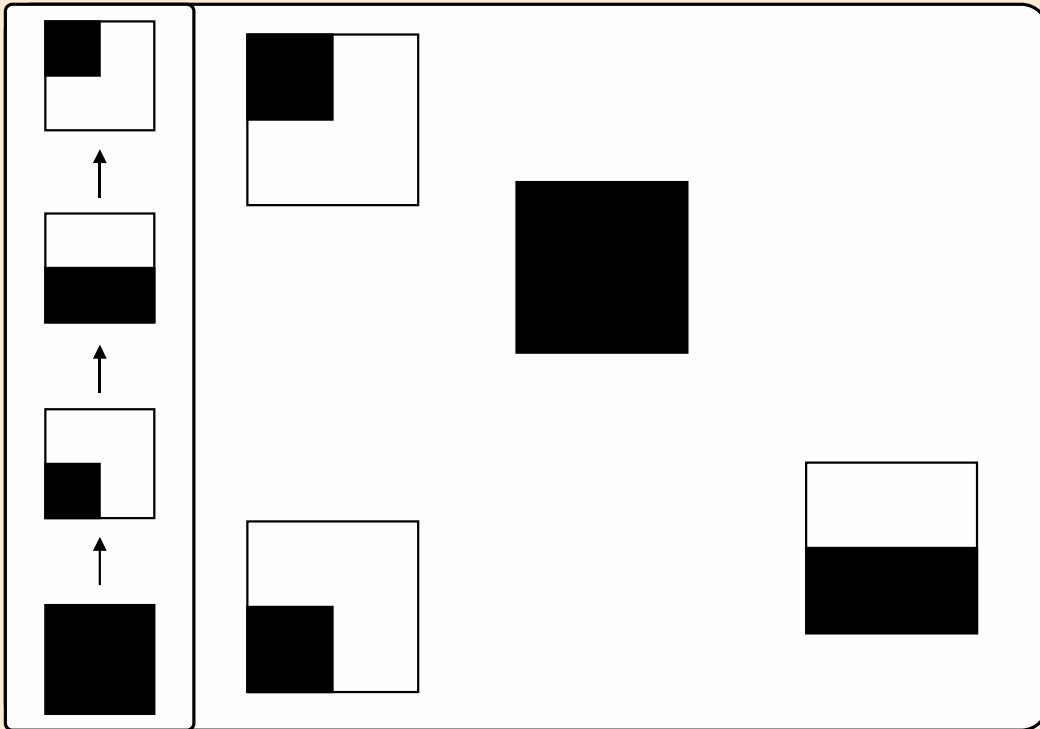

- *Marca lo que corresponde*

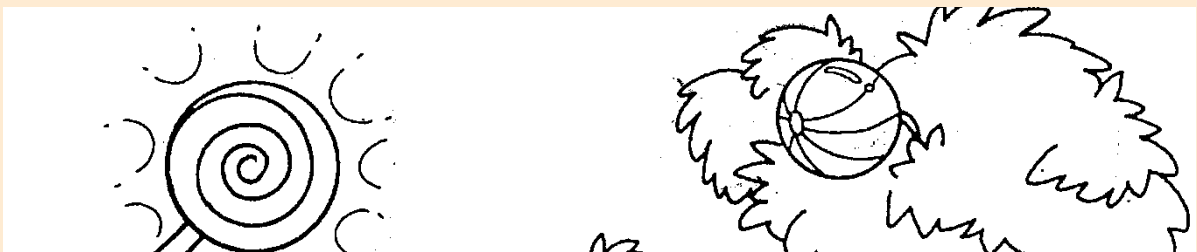





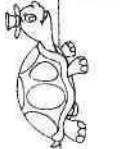

*Orientación*

**ENTRE**

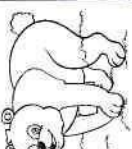
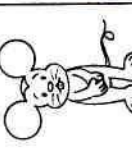
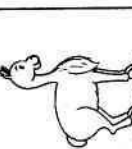
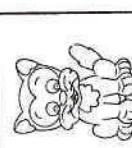
## ¿En qué lugar están?

- Colorea el recuadro de la respuesta correcta, según el lugar que ocupa cada animal.

	9°
	8°
	7°
	6°
	5°
	4°
	3°
	2°
	1°

1°
2°
3°

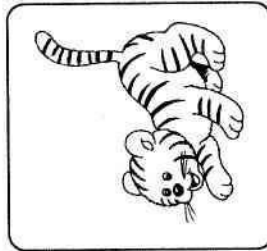

8°
2°
9°

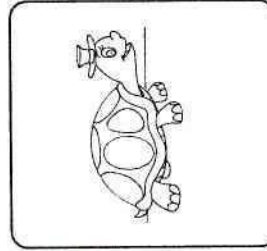

2°
5°
8°

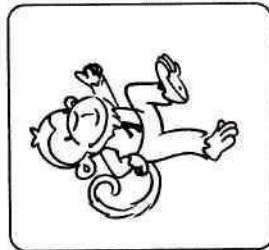

3°
7°
5°

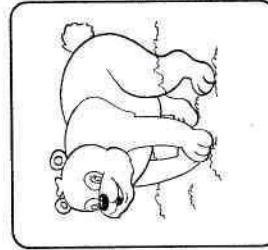

3°
1°
5°

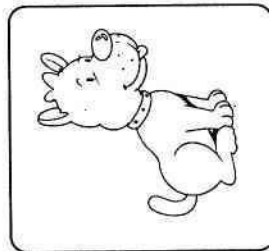

4°
8°
5°

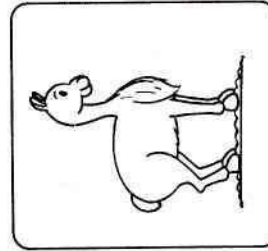



## PARABOLA DEL BUEN SAMARITANO

- Observa, recorta y pega en otra hoja ordenando la secuencia según la parábola.

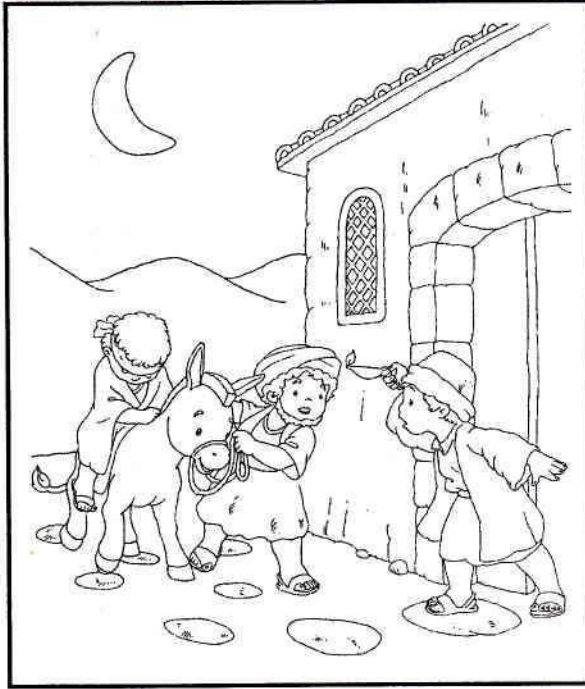

## PARABOLA DEL BUEN SAMARITANO

- Observa, recorta y pega en otra hoja ordenando la secuencia según la parábola.

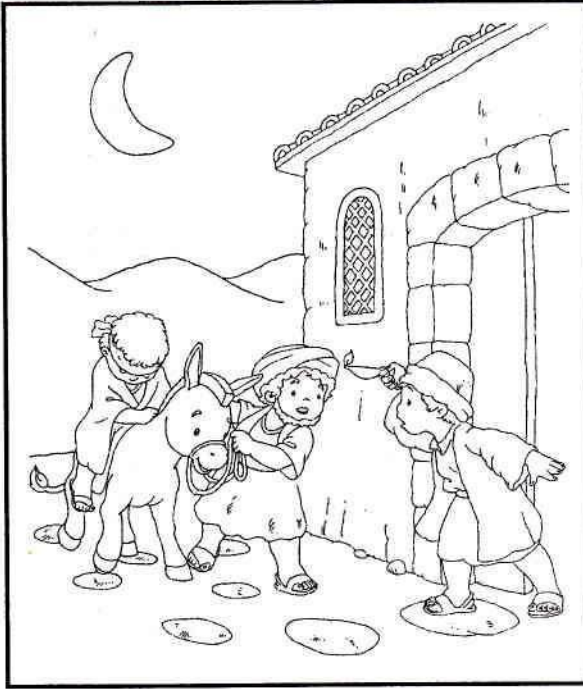

- Observa y comenta
- Colócales números del 1 al 3 según el orden de la secuencia.

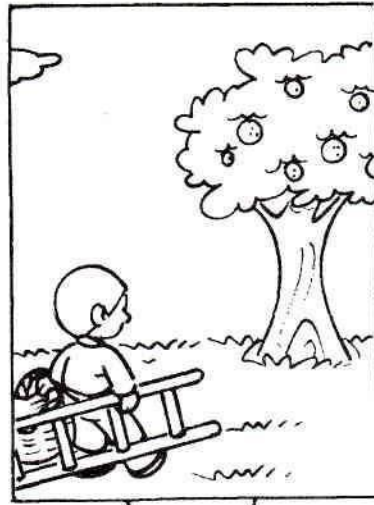

- Recorta y pega las escenas completando las secuencias. Verbaliza lo que sucedió antes y lo que sucederá después.

ANTES

DESPUES

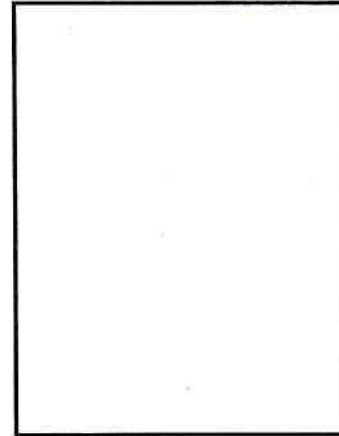
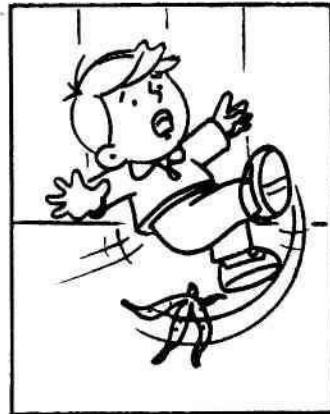
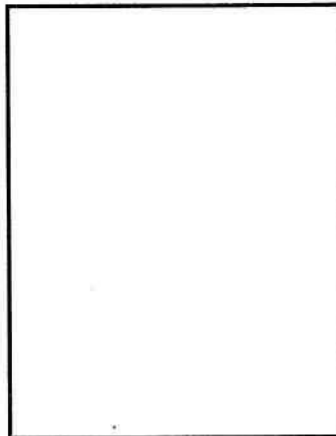
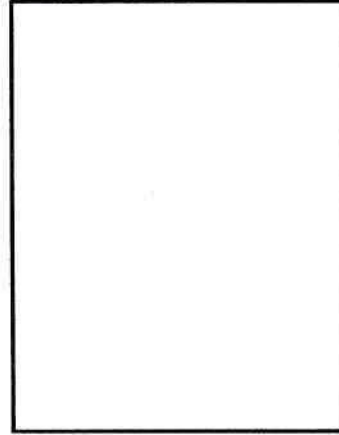
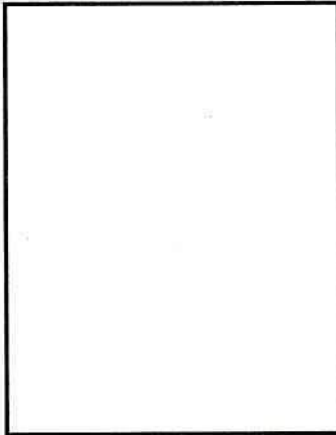

¿CÓMO SON MIS PATAS?

- Observa y realiza el sonido onomatopéyico de cada animal
- Une con líneas de distintos colores cada animal con sus patas respectivas

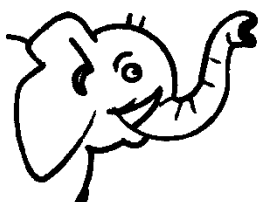

## DORA LA INVENTORA



Un día mientras dormía, tuvo un hermoso sueño.

soñaba que inventaba una

Dora

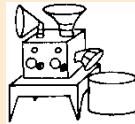

máquina

para hacer enormes



panes

gigantes, que serviría para dar de comer a muchos



pobres

pobres

que tenían hambre. Cuando despertó se dio cuenta



Dora

que su



cerebro

y su inteligencia podían trabajar para

inventar cosas nuevas que ayudarían a toda la humanidad.

1. ¿Con qué soñó Dora?
2. ¿A quién daría de comer su invento?

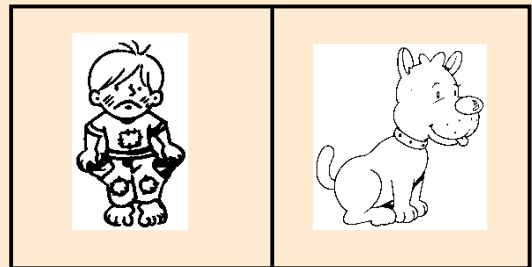
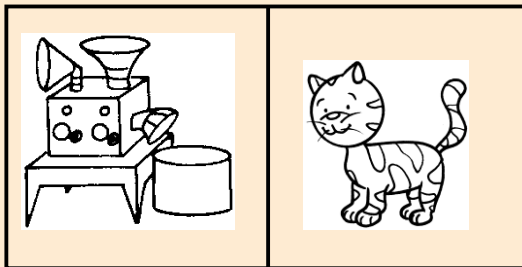

3. ¿Qué usaría Dora para inventar gustaría inventar?

4. ¿Qué cosa te

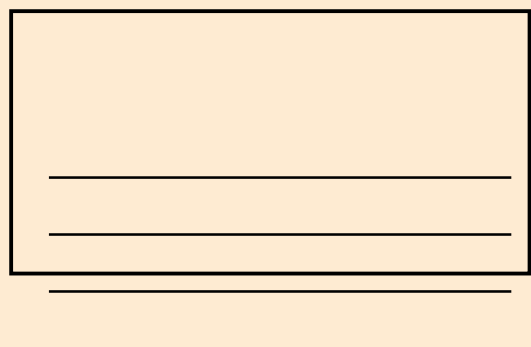

# LENGUAJE

## CANCIÓN DE LAS OCUPACIONES

(Música: Campanero)

Señor policía, señor policía,  
qué hace usted (bis)  
cuido el orden (bis)  
para ti, para ti.

Señor doctor, Señor doctor,  
qué hace usted (bis)  
curo a los enfermos (bis)  
y a ti también (bis)

Señor, bombero, Señor bombero  
qué hace usted (bis)  
apago el fuego (bis)  
por tu bien (bis)

Señor mecánico, Señor mecánico  
qué hace usted (bis)  
arreglo los carros (bis)  
para pasear (bis)

Señor panadero, Señor panadero  
que hace usted (bis)  
amaso la harina (bis)  
para el pan (bis).

- *Ojo: se canta con cualquier ocupación que uno desee.*

## RIMAS

Quando se grande



Marinero quiero ser,  
para el mundo conocer.





¡Cuando sea bombero,  
llegaré yo primero!



¡Seré un buen doctor,  
para quitar el dolor!



¡Profesora quiero ser,  
para que los niño puedan aprender!



¡Seré buena enfermera,  
para ayudar la noche entera!



Seré un buen electricista,  
para que la luz esté siempre lista!

### ADIVINANZA

*¿QUIÉN SERÁ, QUIÉN SERÁ  
EL QUE PINTA SIN DESCANSAR  
PAREDES, MESAS Y PUERTAS  
CON BROCHA, PINTURA Y AGUARRÁS?*

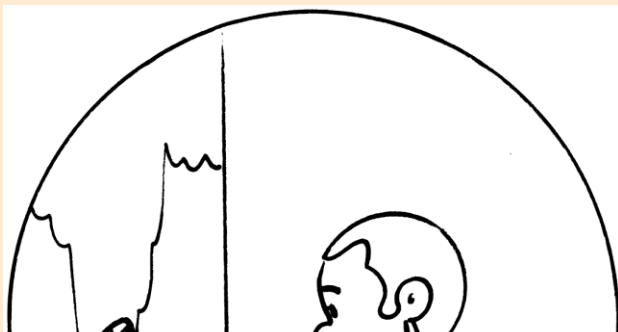



- *Pinta y adorna el recuadro de la respuesta correcta*

# PUPILETRAS

- Busca las palabras y encierra con cuerdas de color diferente

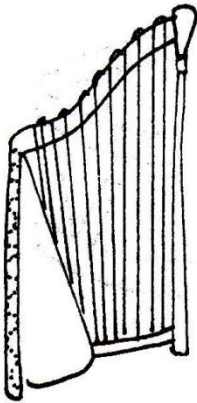

ARPA

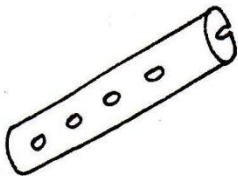

QUENA

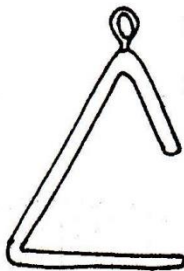

TRIÁNGULO

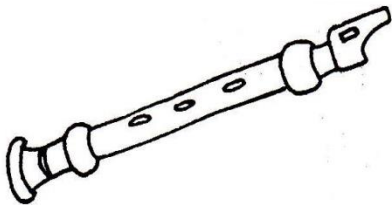

FLAUTA

F	L	A	U	T	A
S	E	U	S	R	L
R	L	T	M	I	V
Q	U	E	N	A	U
G	V	E	I	N	T
U	I	U	J	G	S
A	R	P	A	U	X
O	A	M	A	L	J
S	L	T	O	O	A

## ADIVINANZAS

Me llevan y me traen,  
me tiran y me escogen,  
pero son muy pocos  
los que al final me recogen.

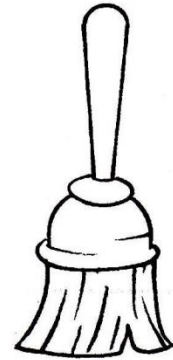

La casa está llena  
de flacos soldados,  
con la cabeza negra  
y bien acostados.

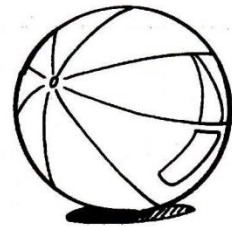

Le das patadas  
y no se enoja,  
cuando entra al arco  
un punto anota.

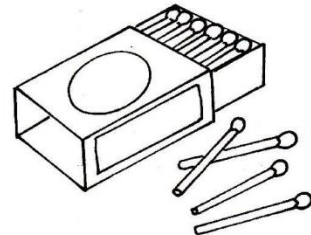

Sale de la sala,  
entra a la cocina,  
meneando la cola  
como la gallina.



• Pinta la figura que completa la rima que lee tu maestra. Luego repite las rimas.

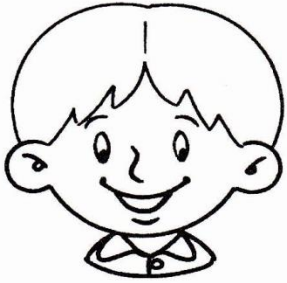

A Simón le duele...



Pie

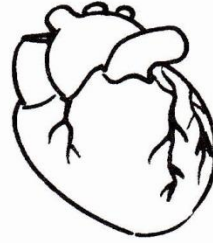

Corazón

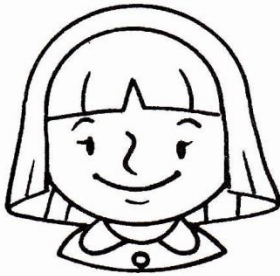

Karina cocina con...

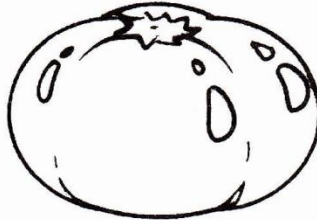

Tomate



Harina



Carolina se baña en la...



Ducha



Tina

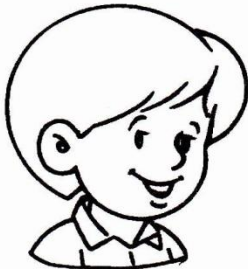

A Renato le aprieta el...

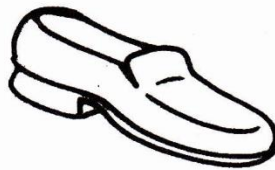

Zapato

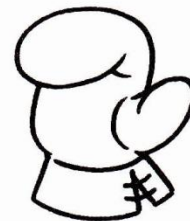

Guante

- Repite el nombre de cada objeto y colorea los círculos según la cantidad de sílabas.

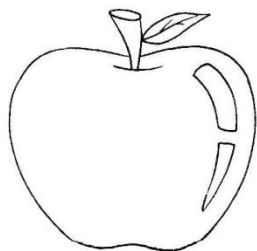
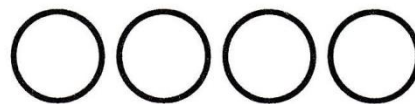
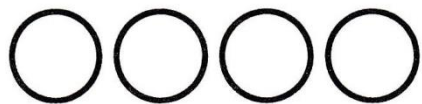
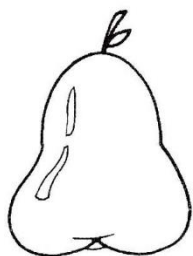
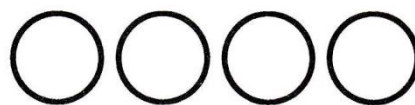
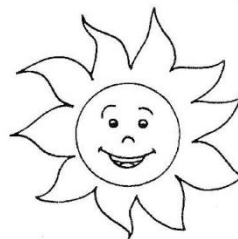
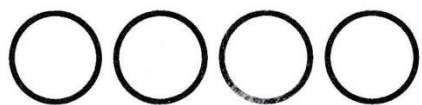
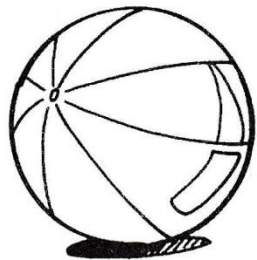

- Nombra los dibujos, marca con palmadas cada sílaba, dibuja una bolita por cada sílaba en el espacio en blanco.

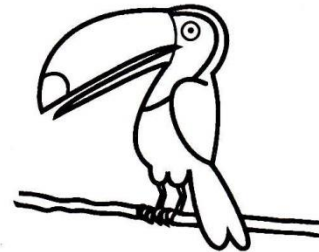
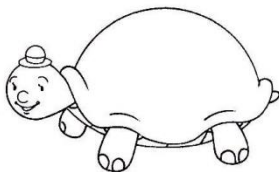
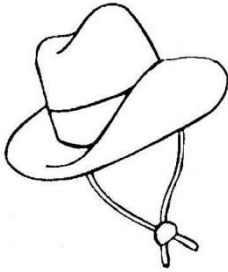
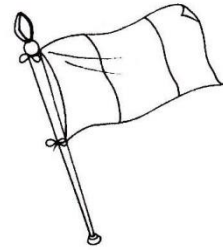

## POESIA



### ¡Algo está demás!

En  casa de los  leones



hay alguien que apareció

y no pertenece al grupo

por ser tan sólo un  ratón.

En mi  caja de  juguetes

hay algo que está demás,

es el  hueso de mi  perro,

no sé cómo llegó acá.

En mi  plato de lentejas

un frejolito encontré,

le dije: ¡vete a tu  plato!

sólo lentejas hoy comeré.

Y así mirando y mirando,

siempre algo encontraré,

que aquí no pertenece

y a su sitio lo mandaré.



# PERCEPCIÓN AUDITIVA: SONIDO INICIAL

- Recorta los recuadros de la parte inferior y pégalos al lado de las figuras con las que tengan el mismo sonido inicial.

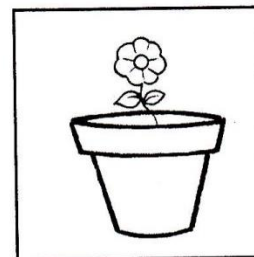
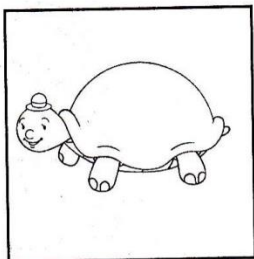
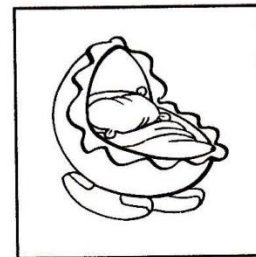
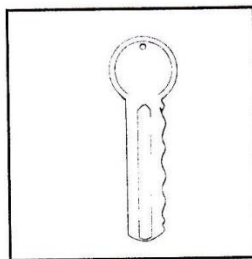
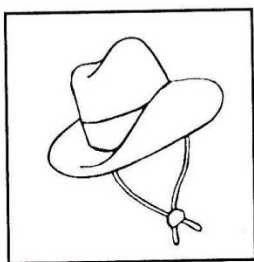
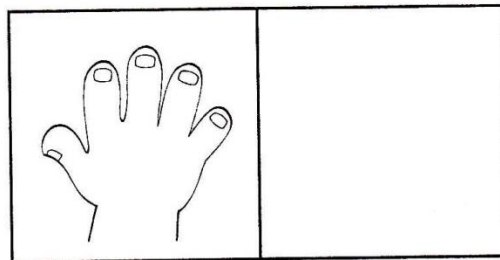
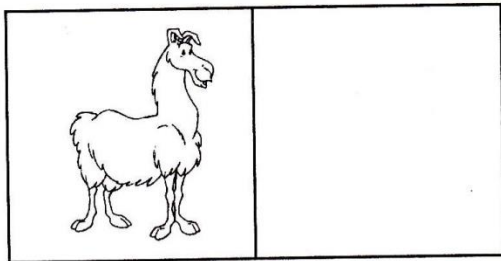
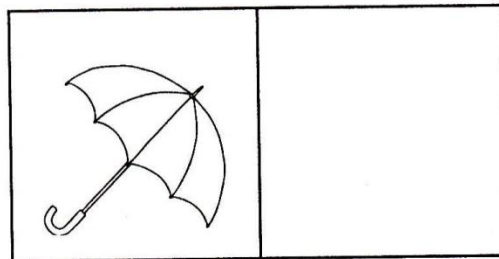
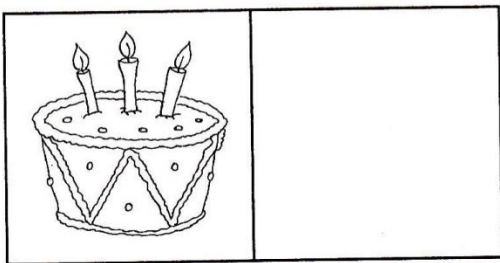
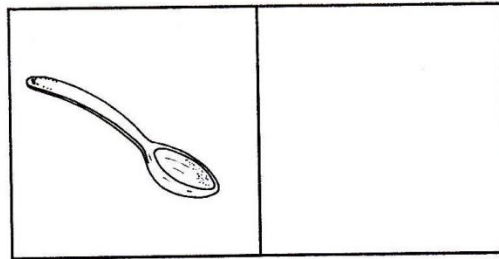
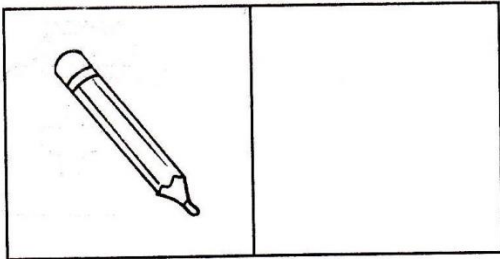

## SONIDO INICIAL

- Observa la figura del centro y pronuncia su nombre repitiendo su primera sílaba. Luego pinta los objetos que comienzan con el mismo sonido.

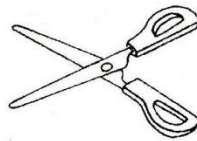
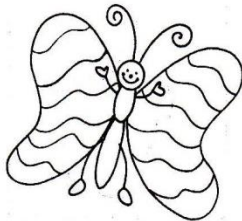
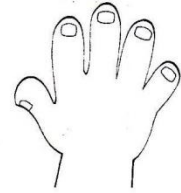
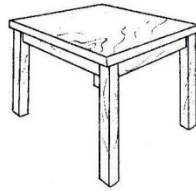
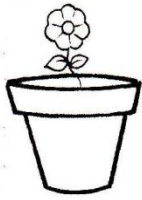

# SONIDO INICIAL

• Colorea los dibujos cuyos nombres empiezan como el primero de la izquierda.

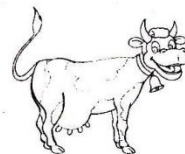
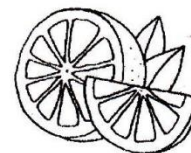
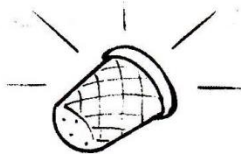
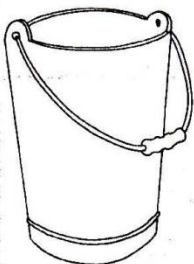
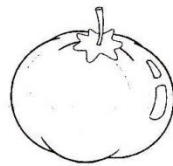
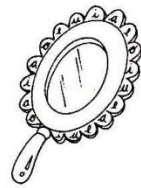
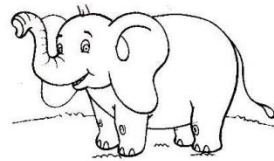
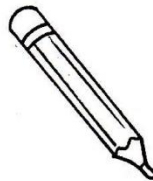
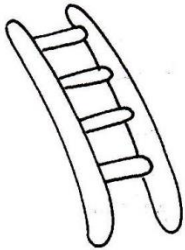
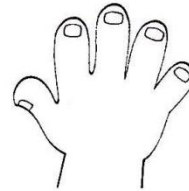
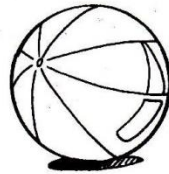
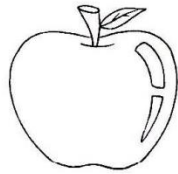
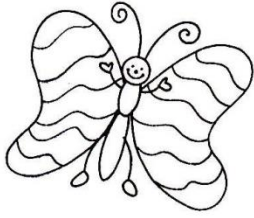





# ORIENTACION

## **EL TESORO DEL PIRATA**

- *El duende encontró una botella en la playa, la cual contenía un plano para llegar al tesoro. Ayudemos al duende a seguir las siguientes indicaciones.*

1º Ubico la palmera

2º Desde el punto

- Avanzo 3  a la derecha
- Avanzo 3  hacia abajo
- Avanzo 4  a la derecha
- Avanzo 8  hacia abajo
- Avanzo 1  a la derecha

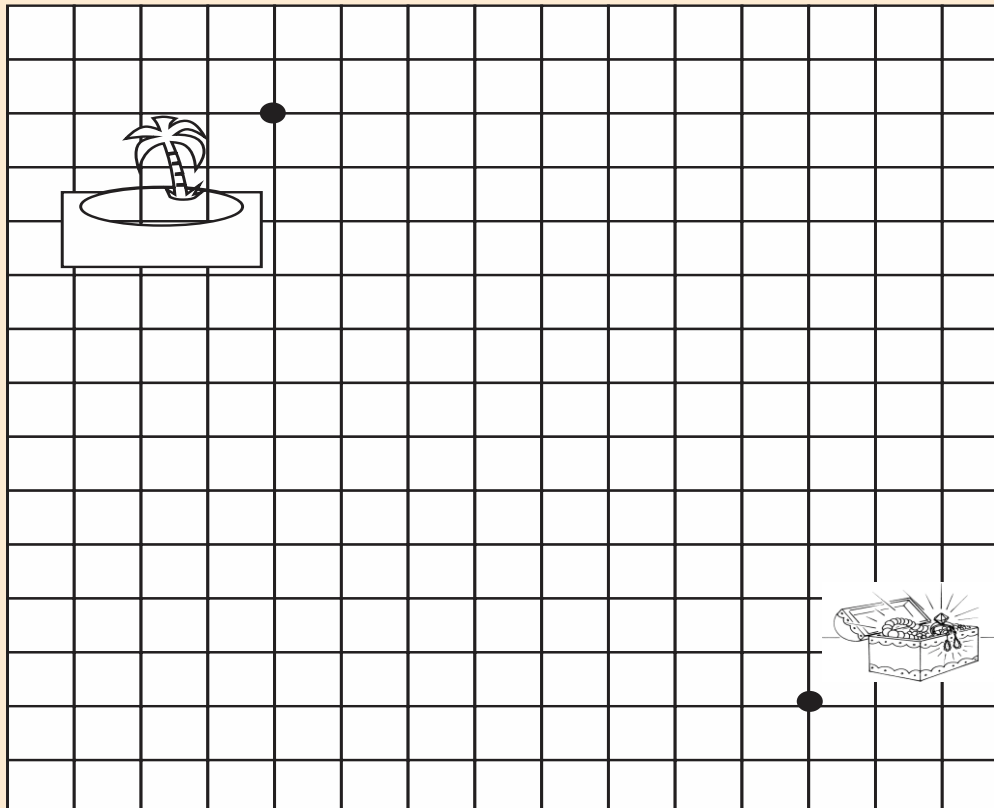
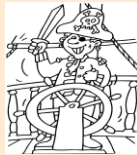

- *En cada ejercicio: Traza el camino en las cuadrículas siguiendo la dirección de las flechas y descubre la figura*
- *En la parte de abajo, encierra la figura que formaste.*

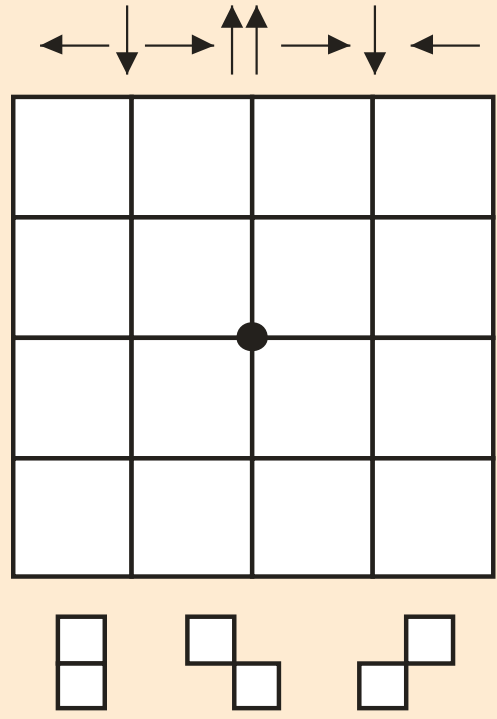
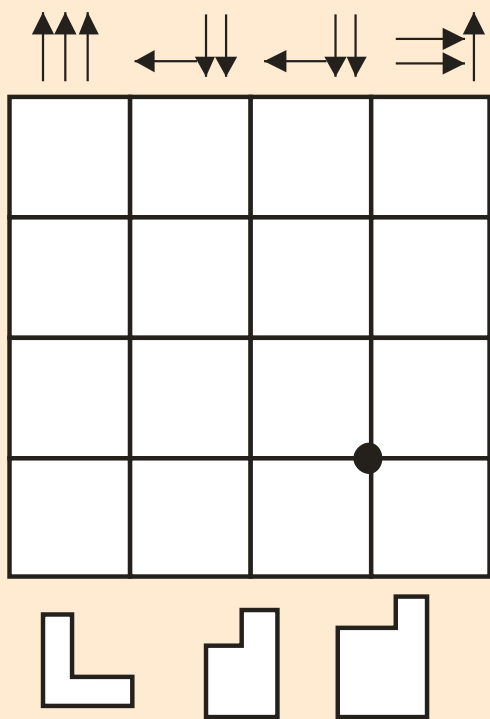
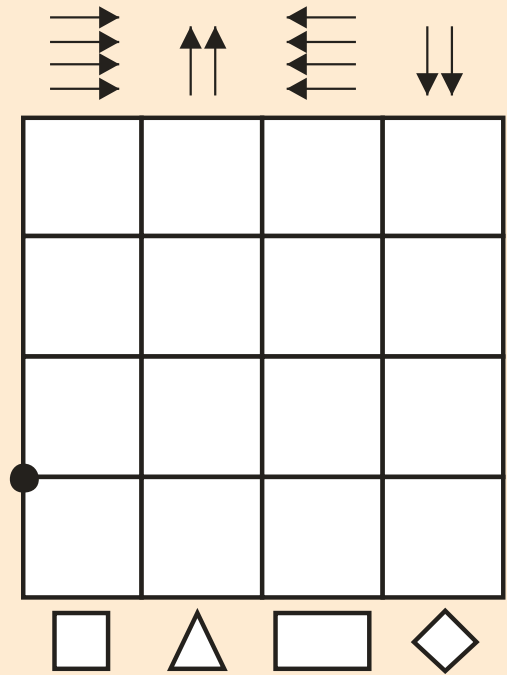
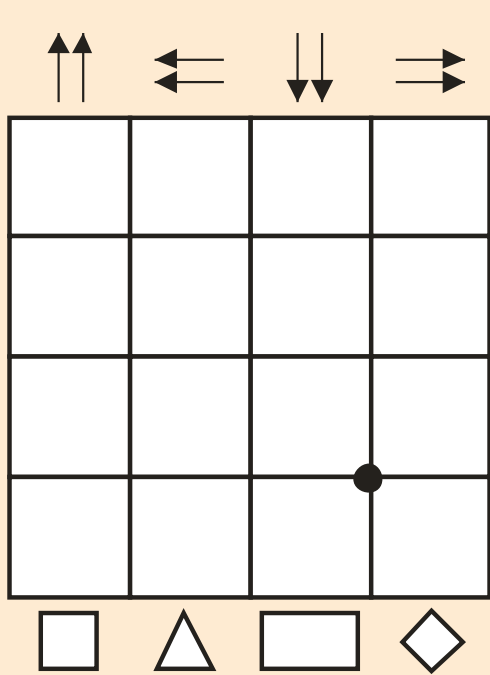

**UBICACIÓN ESPACIAL**

- *En cada ejercicio colorea la respuesta*  
¿Qué juguete está arriba, a la derecha?

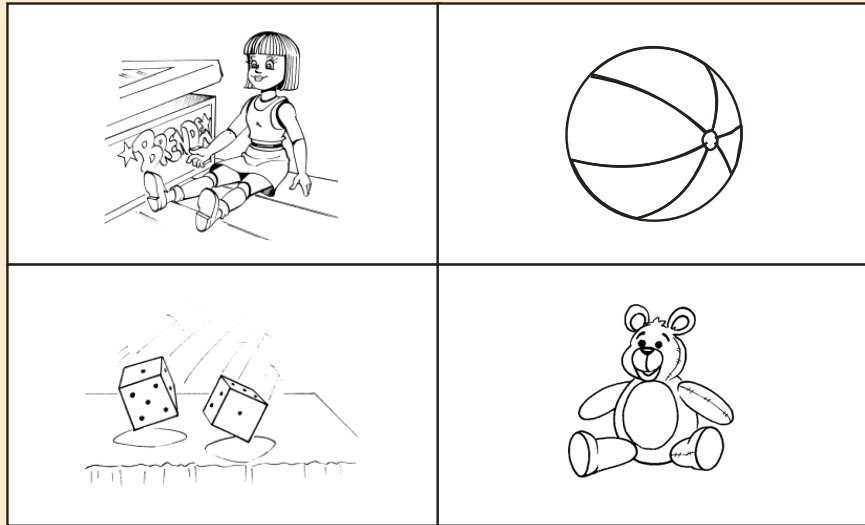

¿Qué útil escolar está abajo, a la izquierda?

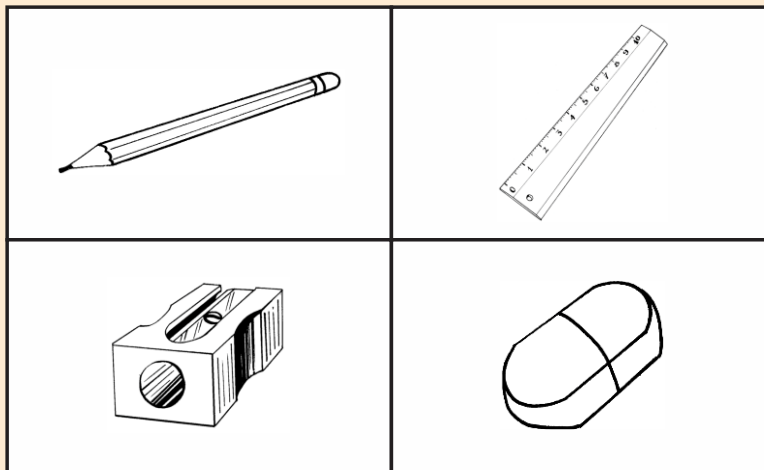

¿Qué útil de aseo está entre el jabón y el caño?

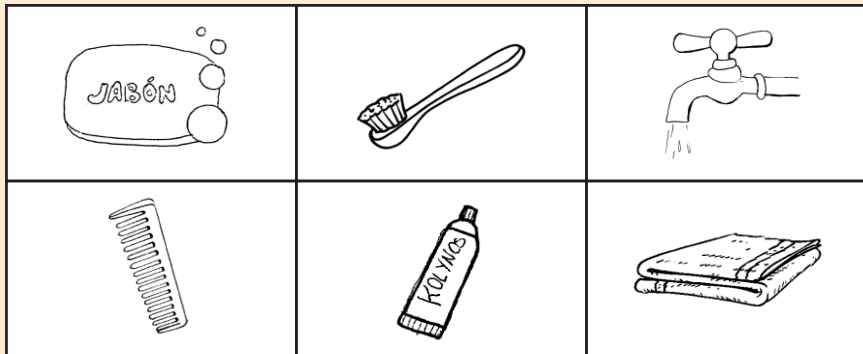

## ORIENTACIÓN ESPACIAL Y TEMPORAL

- Copia cada uno de los dibujos dos veces

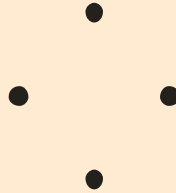
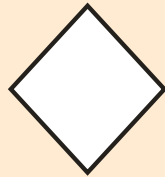
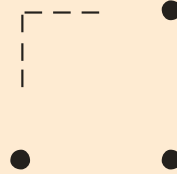
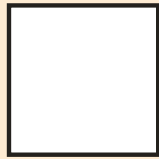
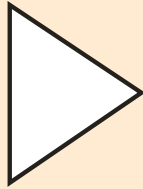
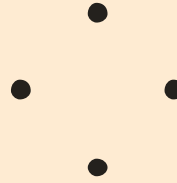
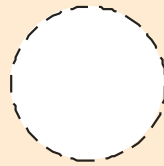
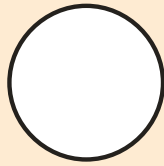

• *Colorea los perritos*

- Arriba a la izquierda verde  
Arriba a la derecha azul
- Abajo a la izquierda amarillo  
Abajo a la derecha rojo

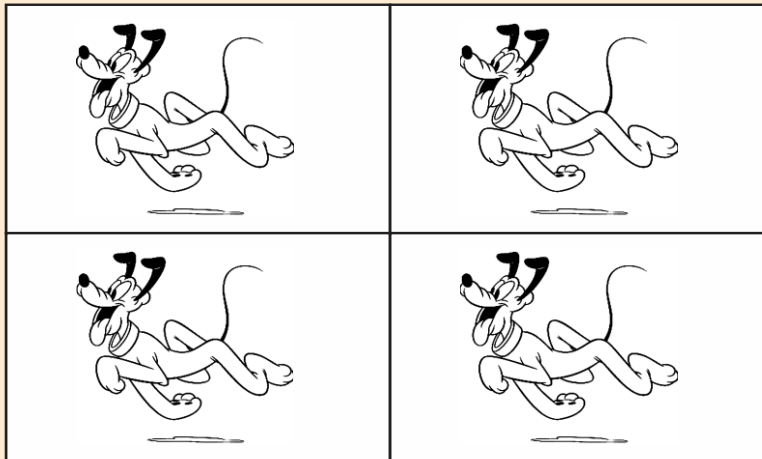

**Atención**

**LARGO - CORTO**



- Recorta las correas y pégalas ordenándolas de la más larga a la más corta.  
Pinta

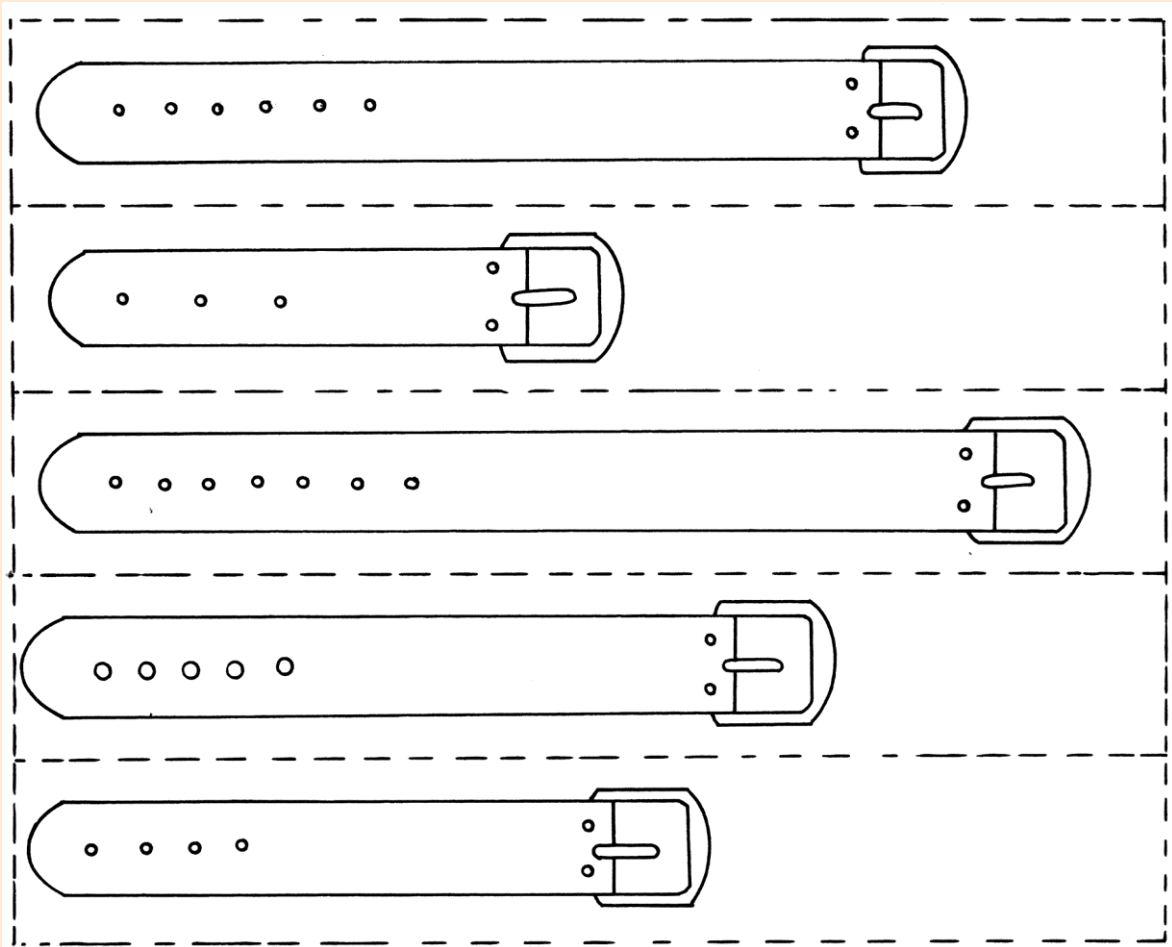

- Observan, recortan, comparan y pegan, ordenando a las niñas que tienen faldas de la más corta a la más larga

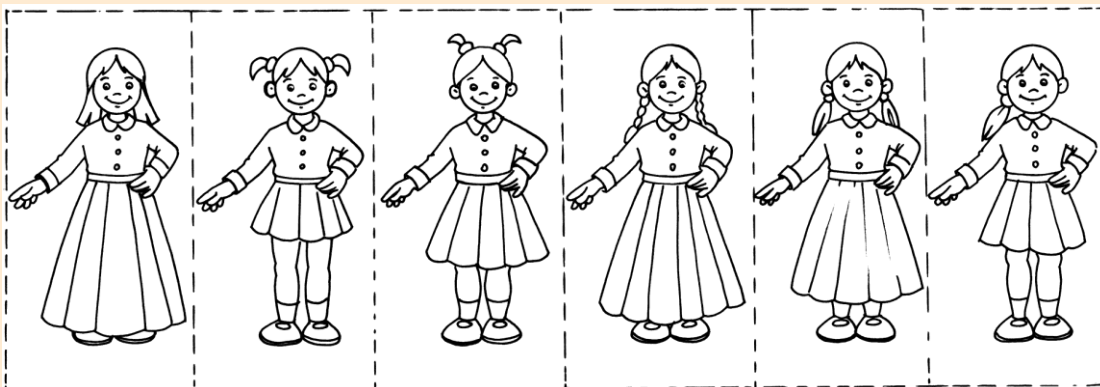

### DESCENDENTE

- Recorta y pega del más alto al más bajo

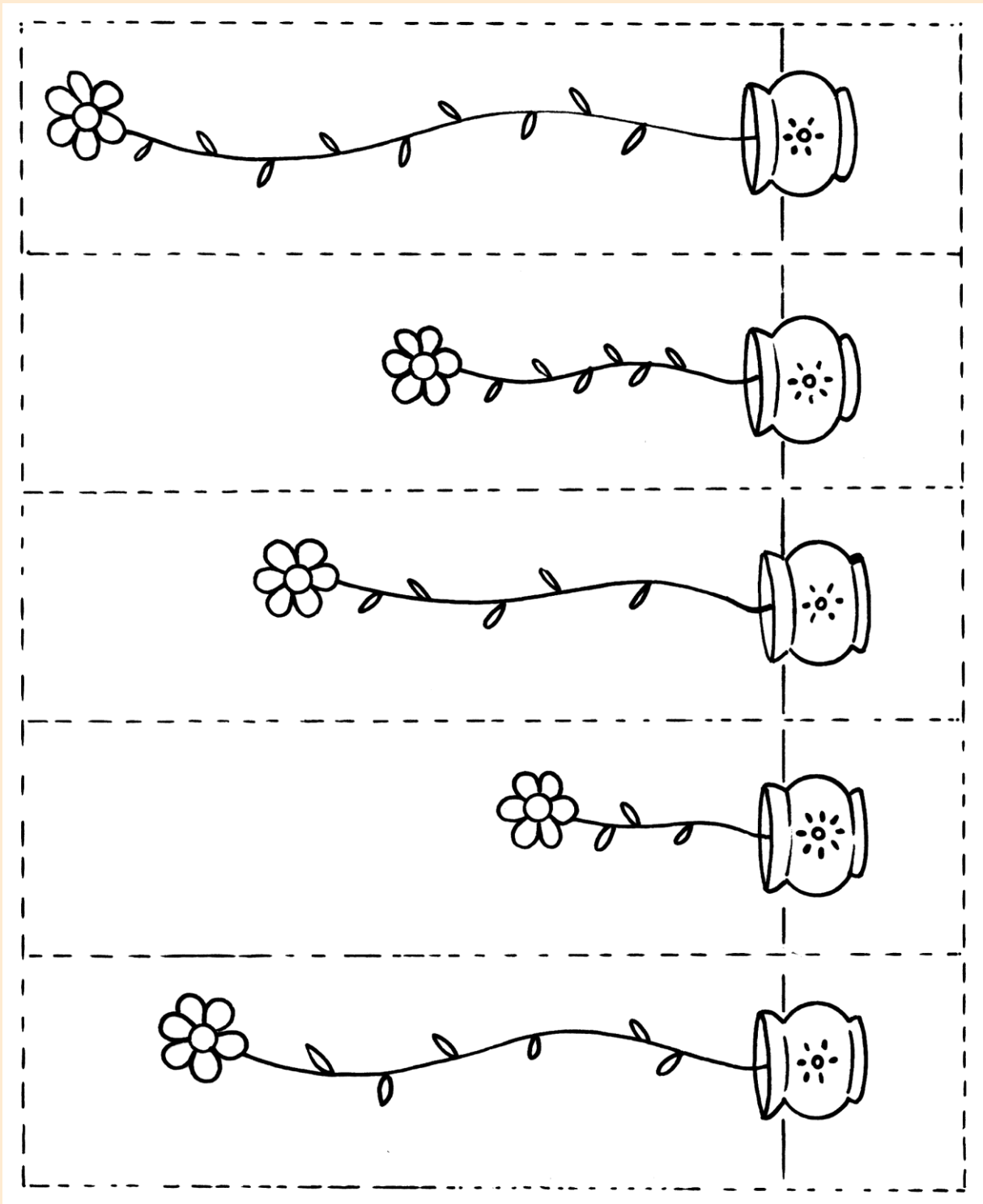

• *Pinta lo que está entre el hongo y la flor*

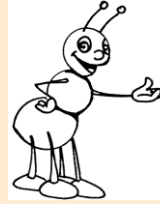

- *Pinta lo que está entre el polo y el pantalón*

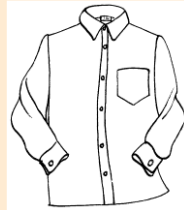

- *Pinta lo que está entre la pelota y la motocicleta*

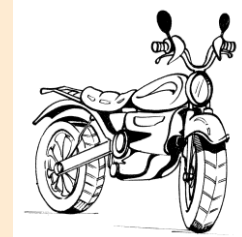
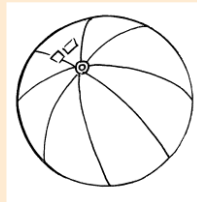
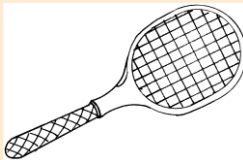

- *Dibuja un juguete entre el cohete y el oso*



**DELANTE – DETRÁS**

Pega los niños delante de la profesora

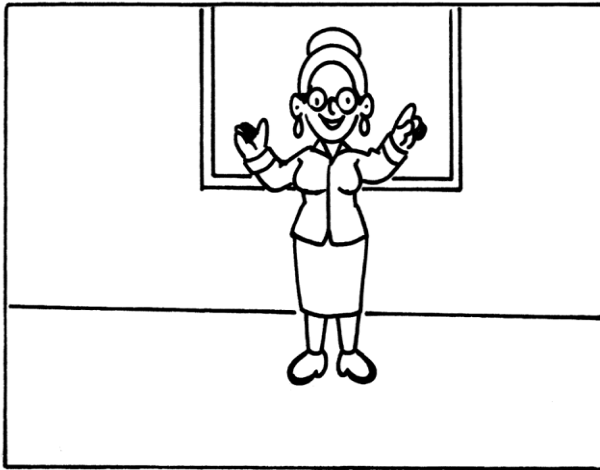

Colorea los niños que están delante del sacerdote



Pega los pollitos detrás de la gallina

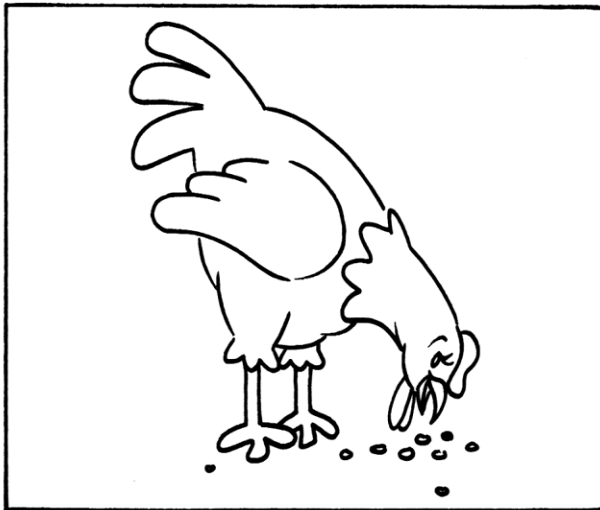

Colorea los hongos que están detrás del gusano.

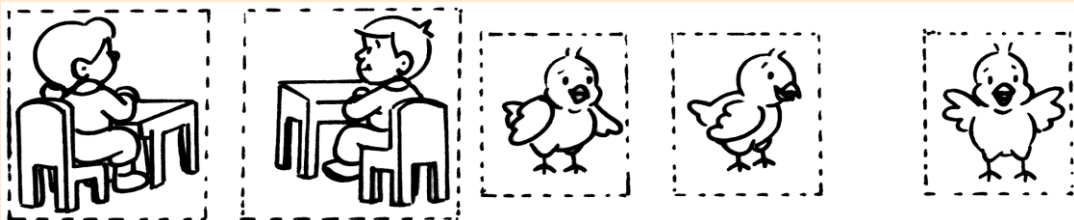
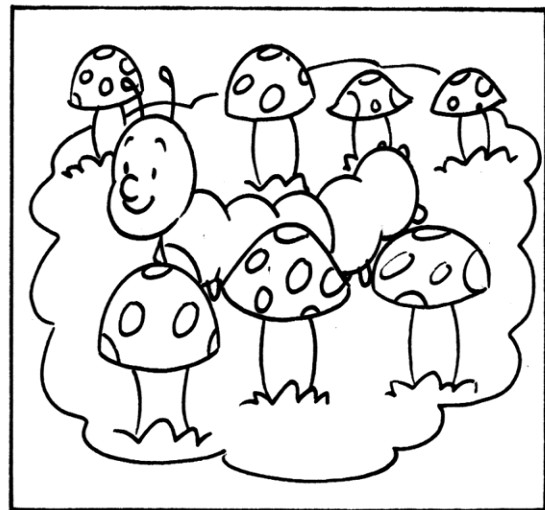

• Encierra lo que está dentro de





- *Marca los elementos que están fuera*

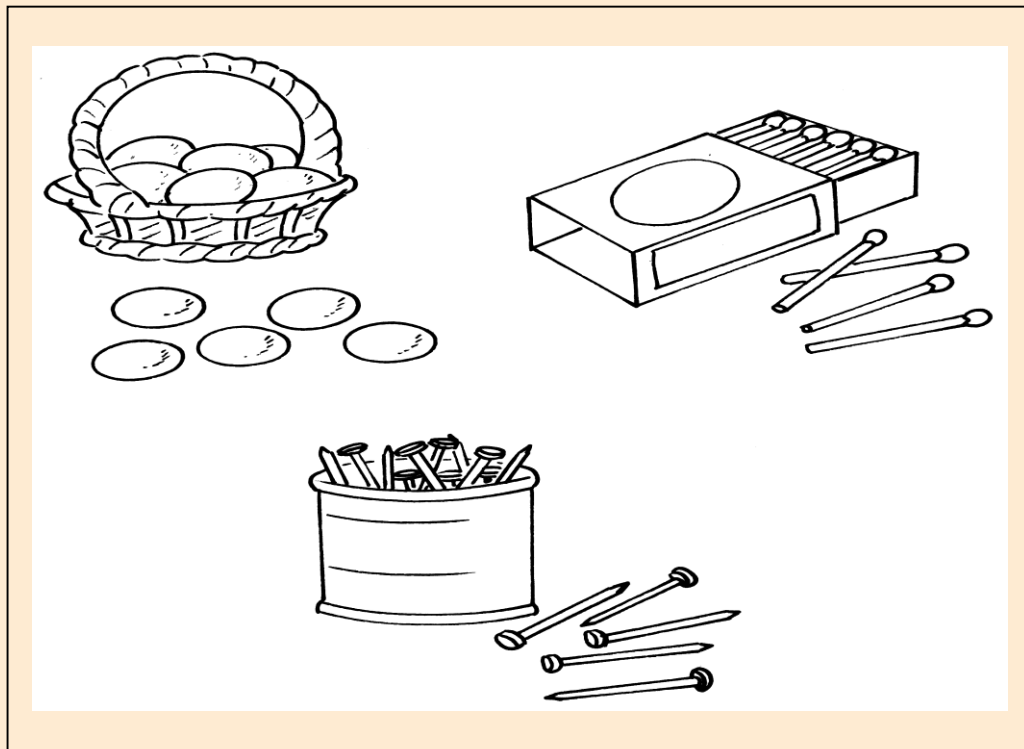

**ENCIMA – DEBAJO**

- *Pinta las figuras que están encima*
- *Encierra las figuras que están debajo*

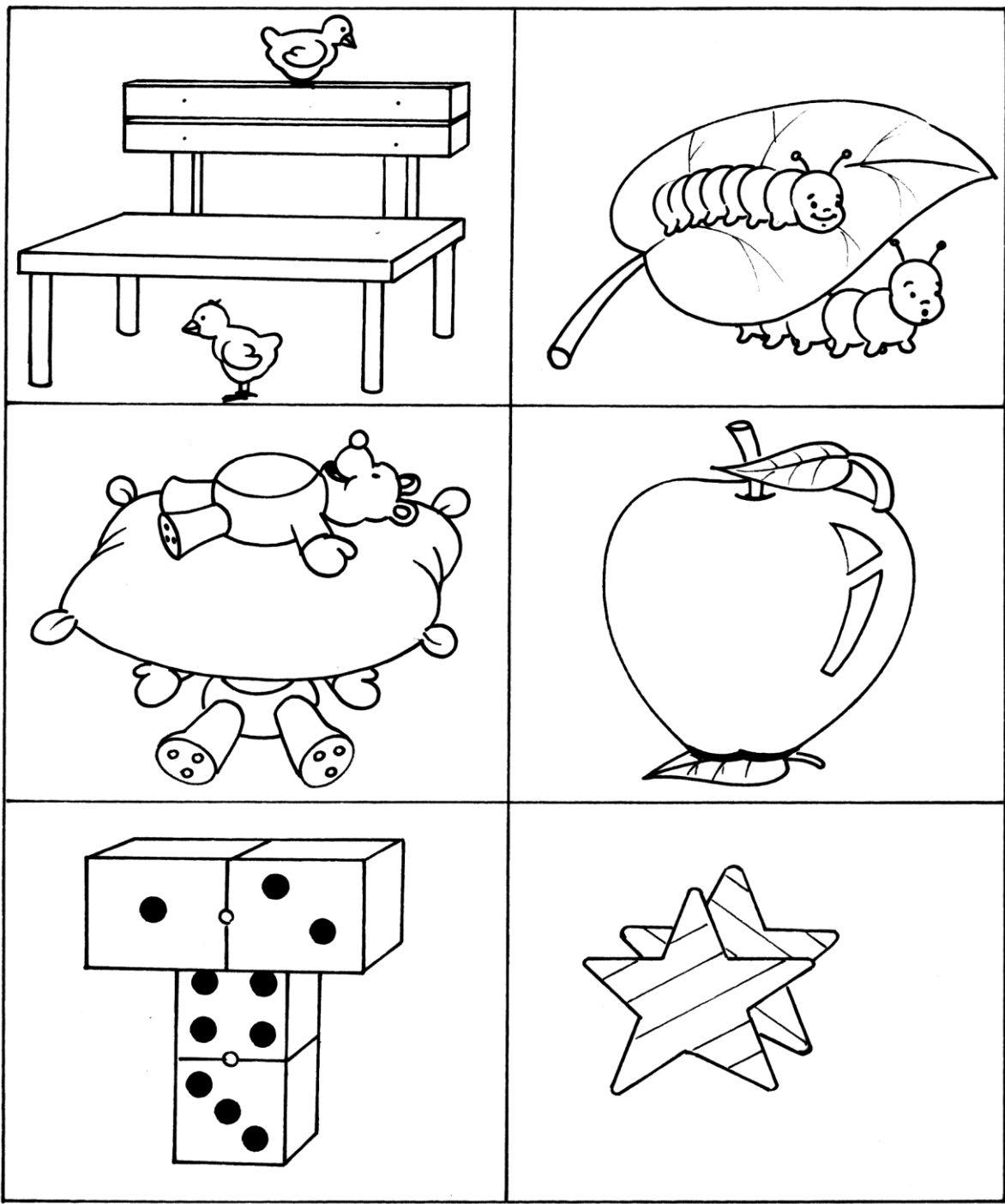

# MEMORIA

## CUENTO HASTA 20

- *Pinta el gato y el regalo según la clave.*

verde	rojo	amarillo	anaranjado	rosado	morado	azul	marrón	celeste	plomo	negro
10	11	12	13	14	15	16	17	18	19	20



## UNA MÁQUINA ORIGINAL

- *Observa y comenta ¿qué vez en la escena?*
- *Escribe los números en la máquina según la clave. Pinta la máquina según la clave de colores.*





rojo	1
amarillo	2
rojo	3
verde	4
negro	5
rojo	6
rojo	7
plomo	8
amarillo	9
verde	10

verde	11
rojo	12
rojo	13
azul	14
plomo	15
amarillo	16
anaranjado	17
negro	18
rojo	19
azul	20

# RAZONAMIENTO

• Copia los códigos según el modelo

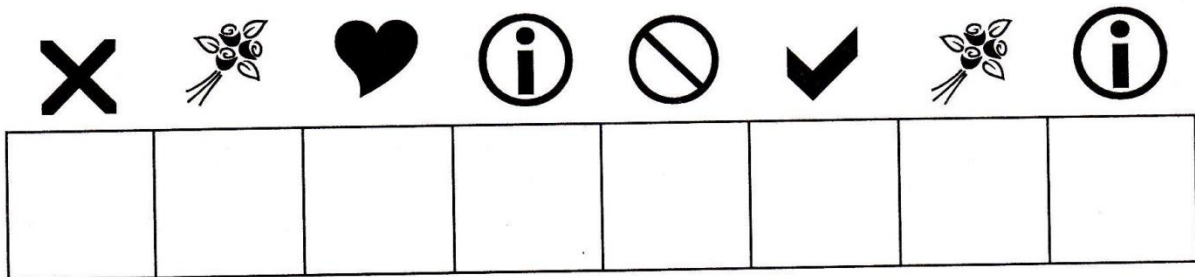
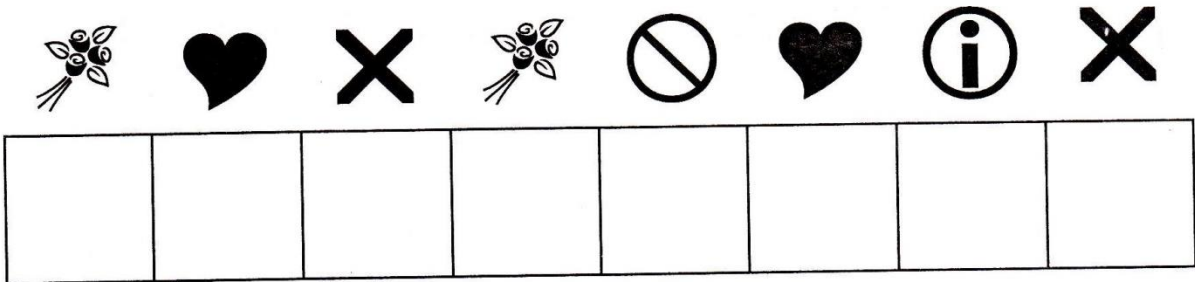
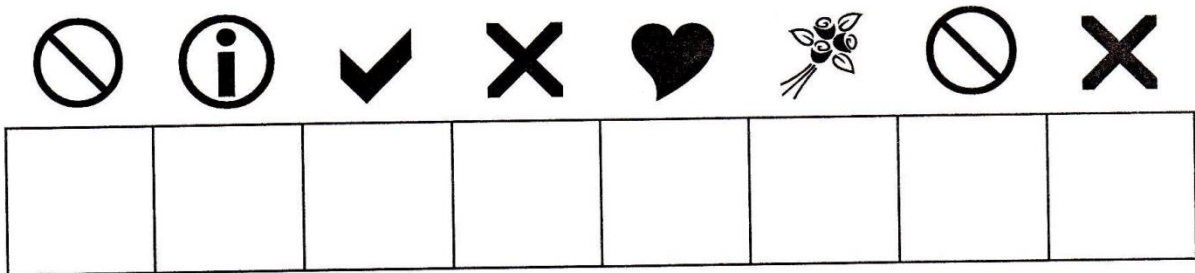
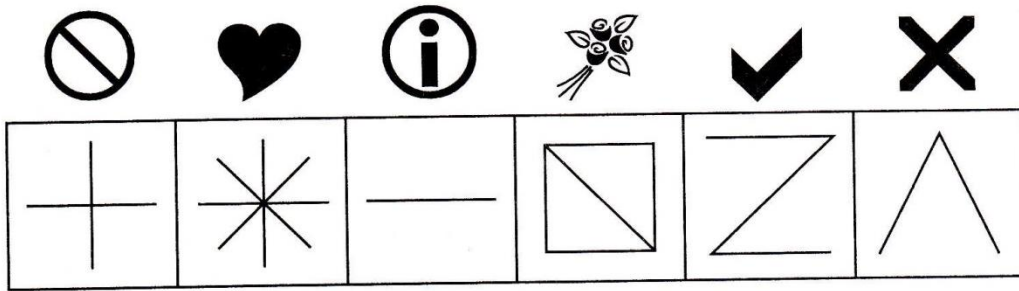

# SECUENCIA POR COLOR

- *Observo cada caso y colorea completando la secuencia.*

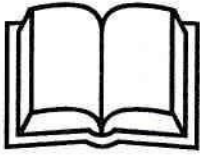

ROJO

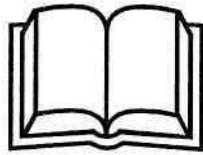

AMARILLO

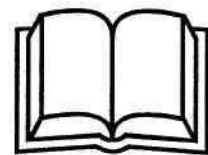
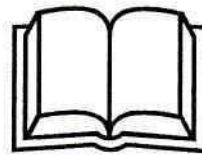

VERDE

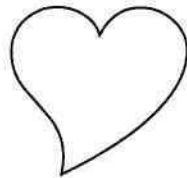

MORADO

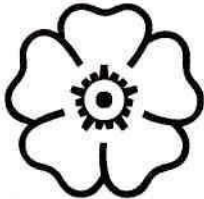
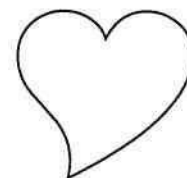
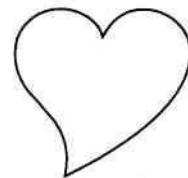

CELESTE

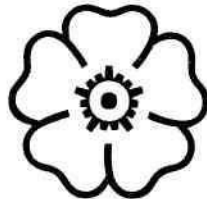

ANARANJADO

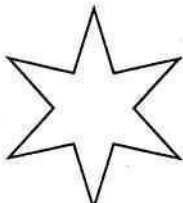
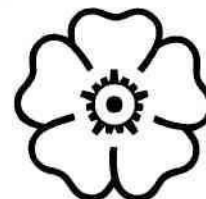
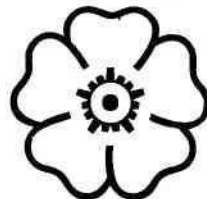

BLANCO

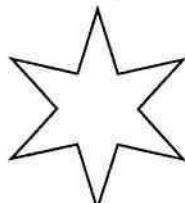

MORADO

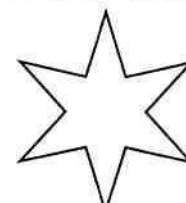
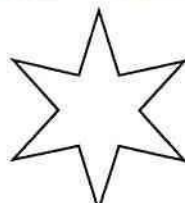

ROSADO



AZUL



## SERIACIÓN

- Pinta las figuras, luego une cada jirafa con el árbol que le corresponde, utiliza diferentes colores.

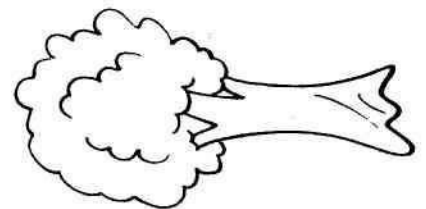
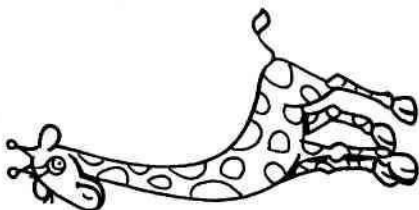
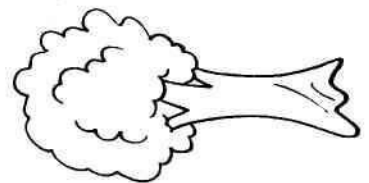
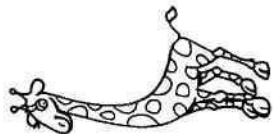
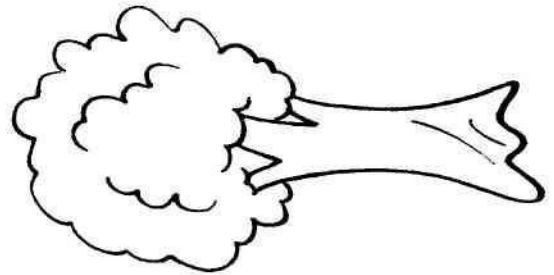
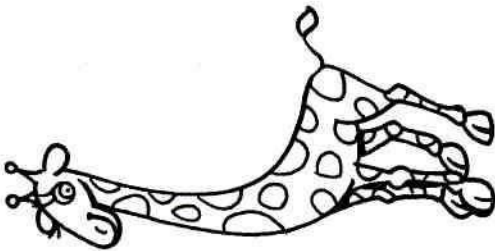
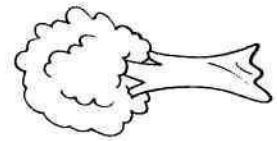
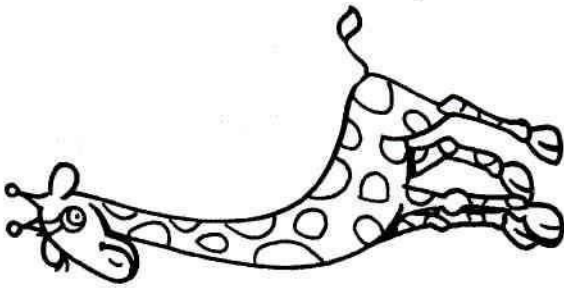
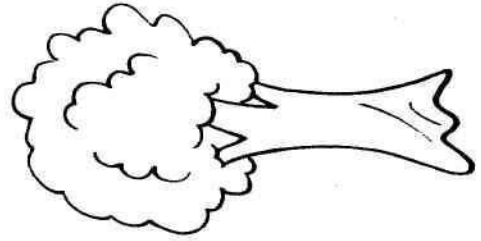
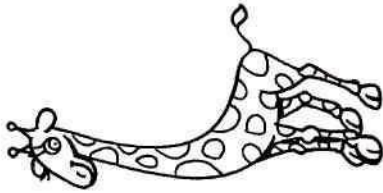
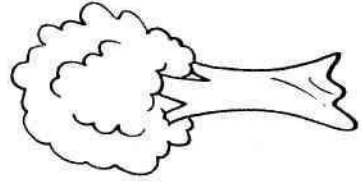
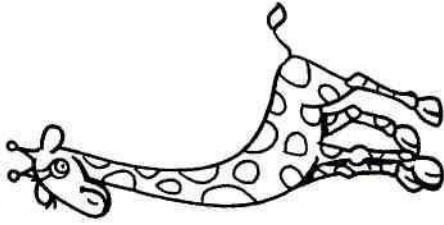

# CUENTO Y UNO

- Cuenta, en cada caso la cantidad de frutas que hay y une con el número correspondiente.

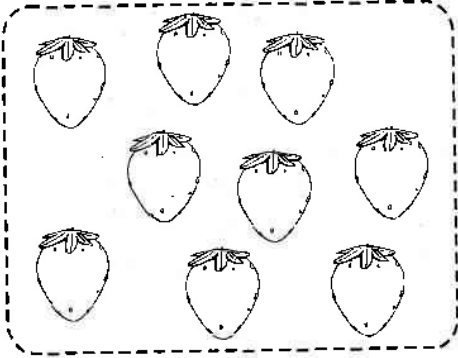

• 5

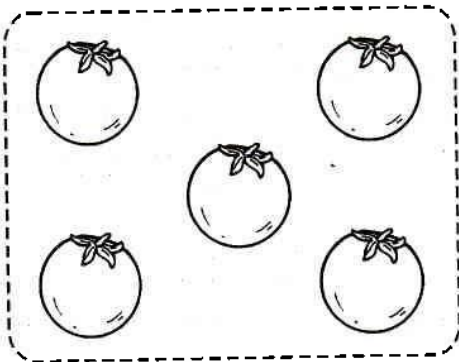

• 8

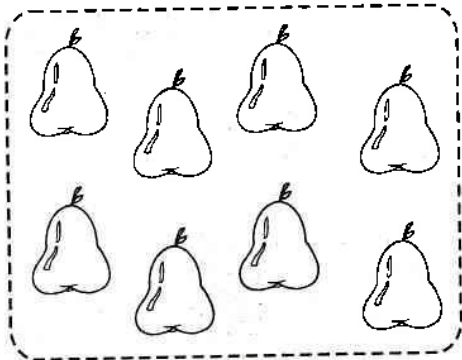

• 7

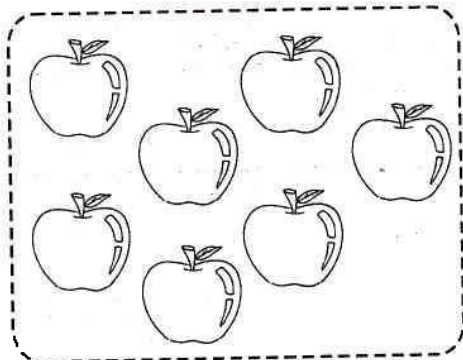

• 9

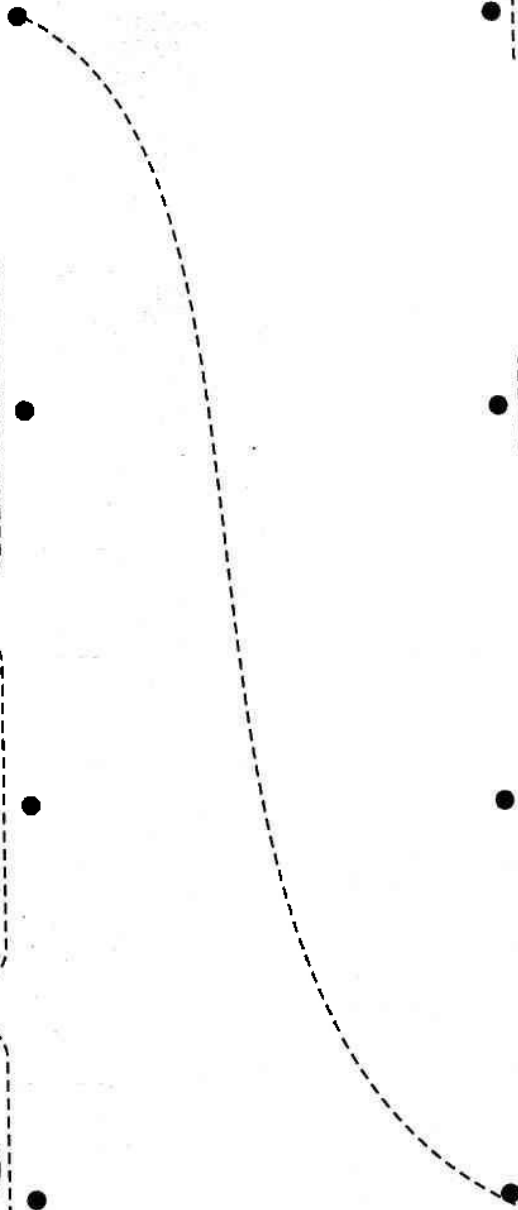

ATENCIÓN

- Encierra las que son iguales al modelo

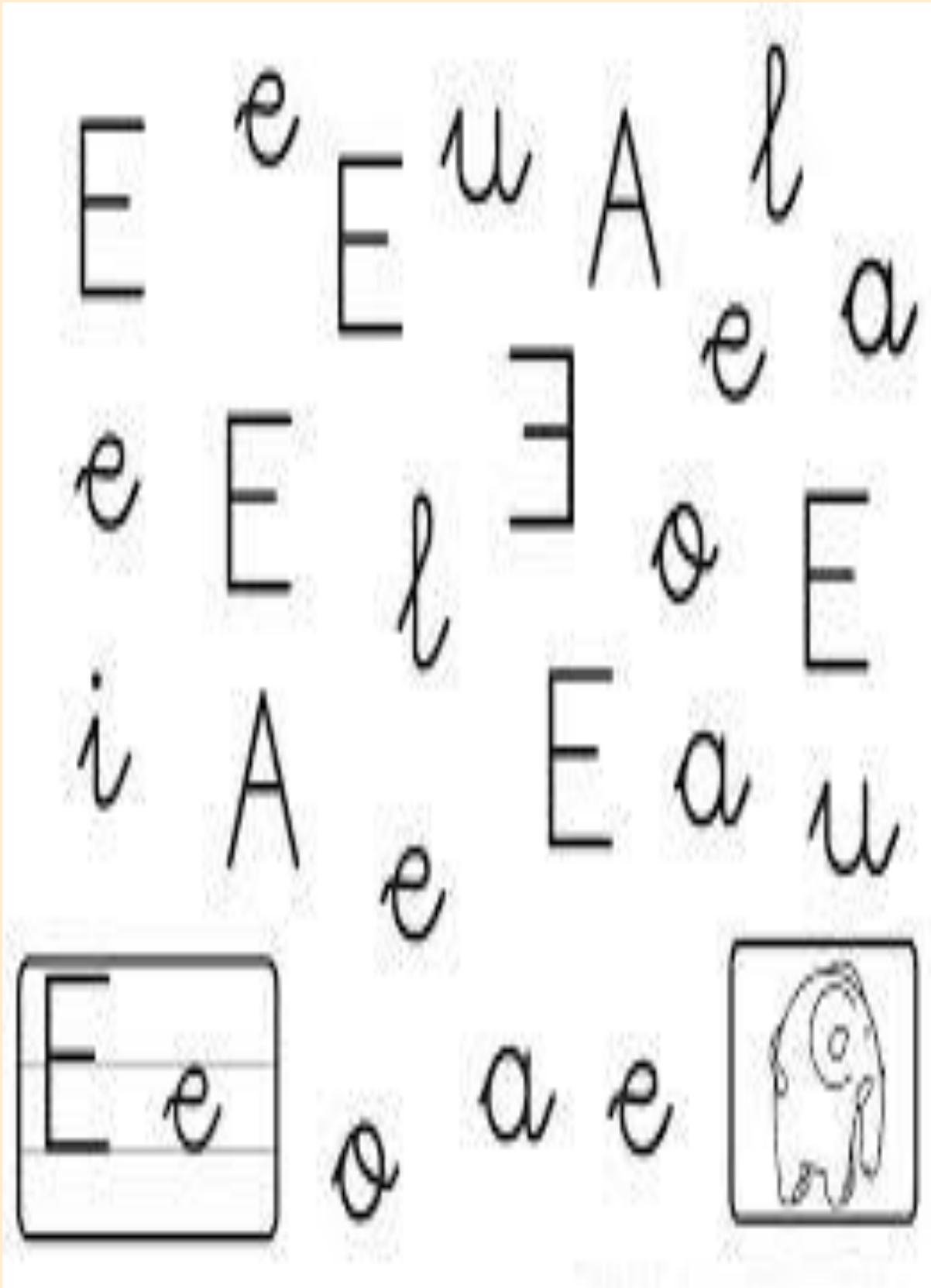

# ¡QUÉ LÍO!

DESCUBRE LOS OBJETOS ESCONDIDOS SIGUIENDO LA LÍNEA DE PUNTOS CON UN LÁPIZ.  
USA UN COLOR DIFERENTE PARA CADA FIGURA QUE ENCUENTRES.

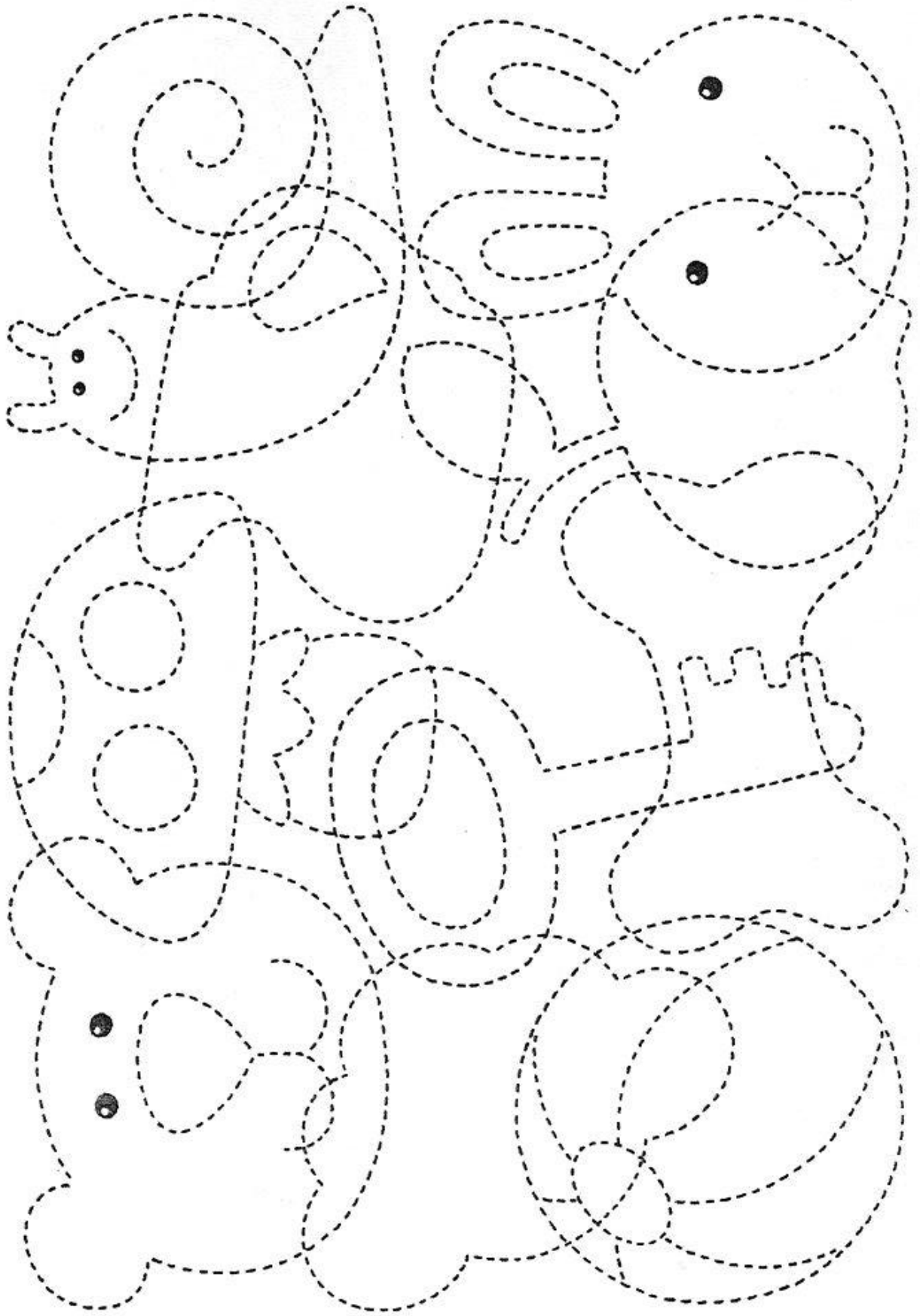



# ANA Y PEDRO

COMPLETA LA CARA Y LA ROPA DE CADA UNO DE ESTOS CHICOS. COLOREA COMO MÁS TE GUSTE.

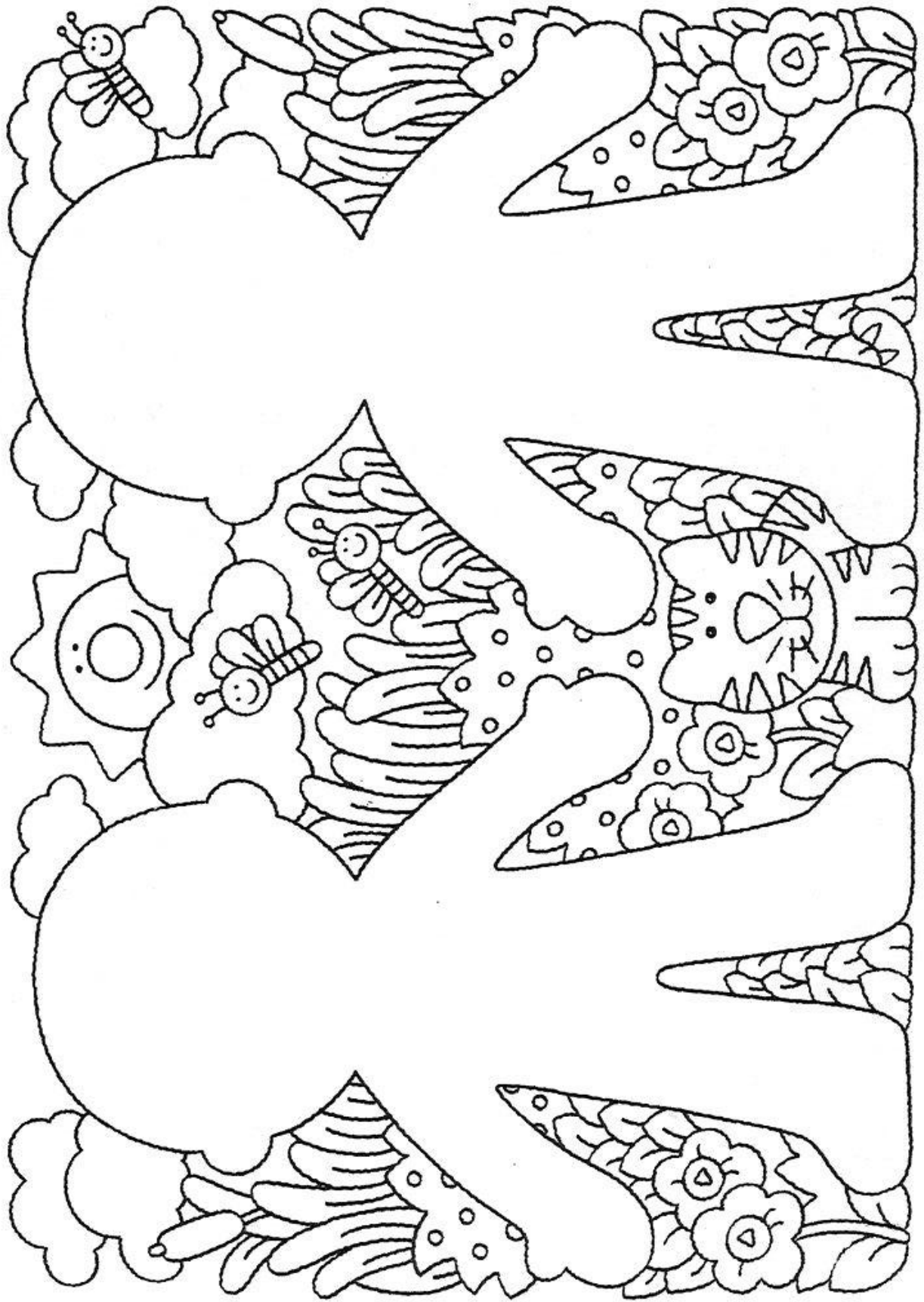

# OJOS, NARICES, BOCAS Y BIGOTES

COMPLETA CADA UNA DE ESTAS CARAS COMO MÁS TE GUSTE. ¿PUEDES NOMBRAR CADA ANIMAL?

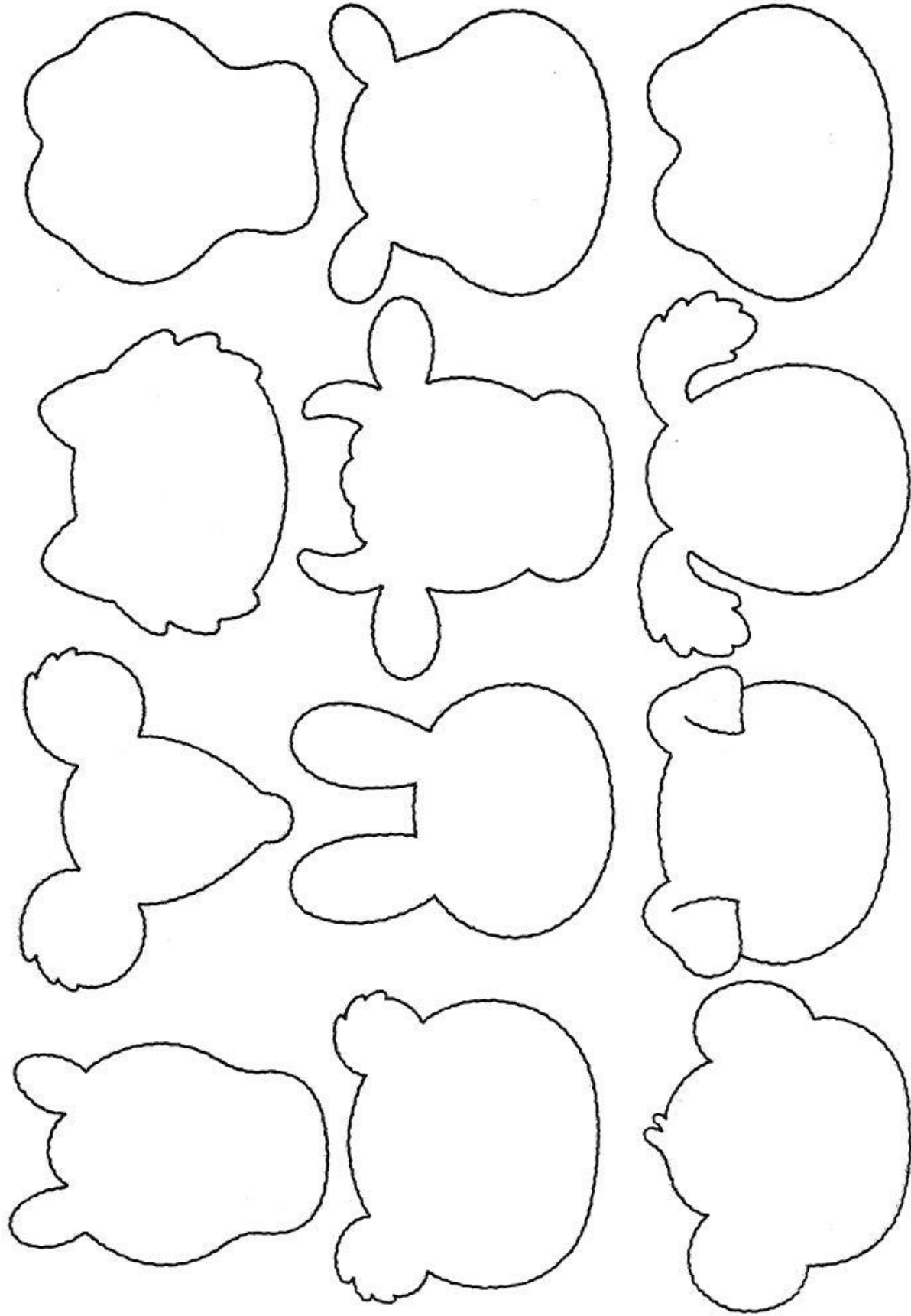

# ANIMALITOS REUNIDOS

¿PUEDES NOMBRAR ESTOS ANIMALES? COLOREA AQUELLOS QUE VIVEN EN EL MAR.

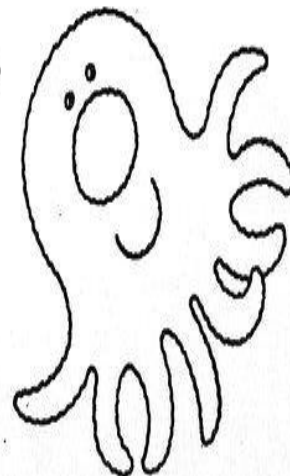
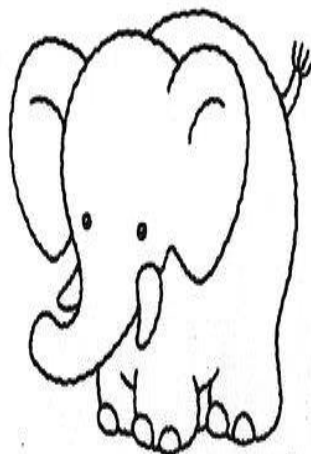
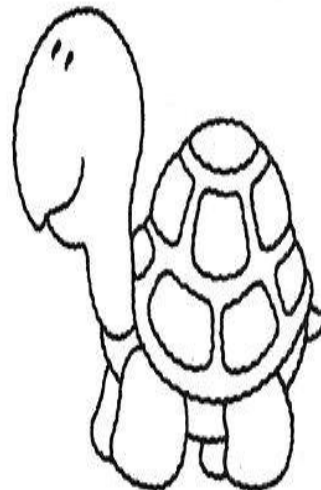
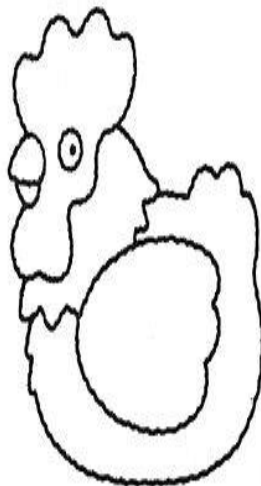
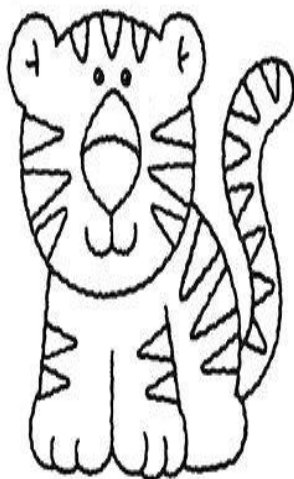
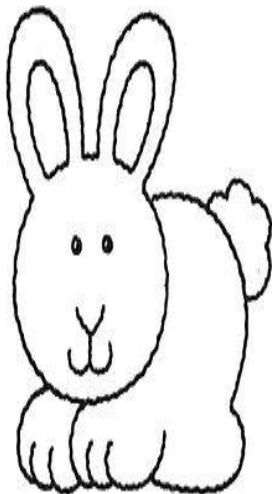
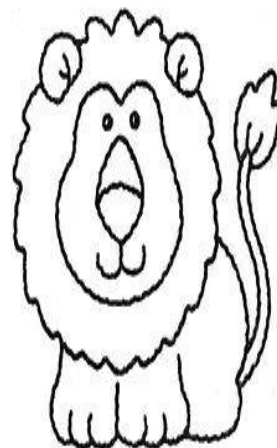
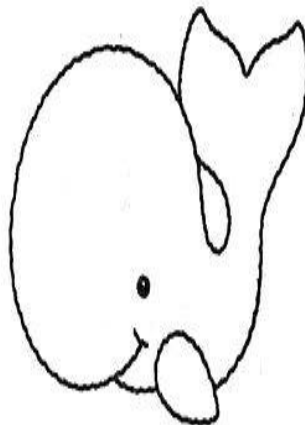
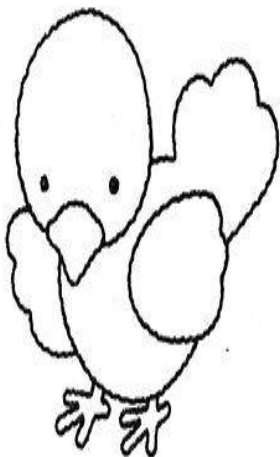
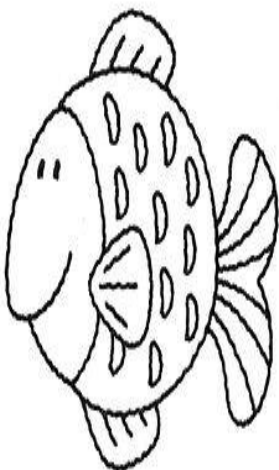

# CARAS Y CARITAS

41

OBSERVA CON ATENCIÓN CADA CARA Y COMPLETA LO QUE LE FALTA.

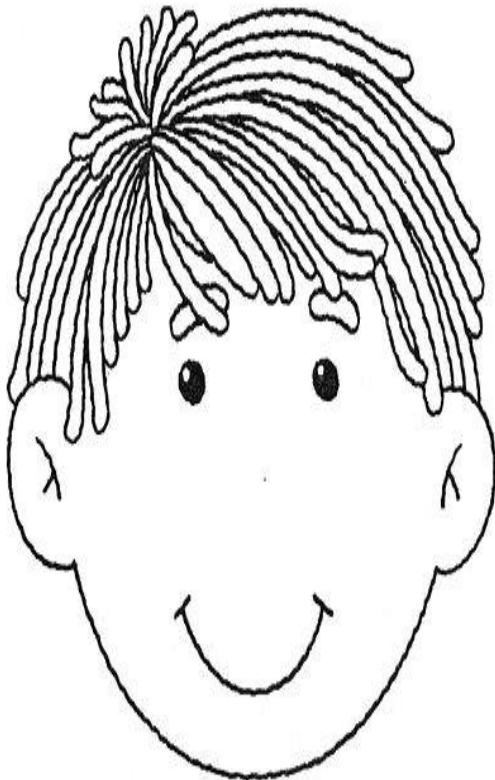

# DOS CHICOS AMIGOS

COMPLETA Y COLOREA ESTAS DOS FIGURAS.

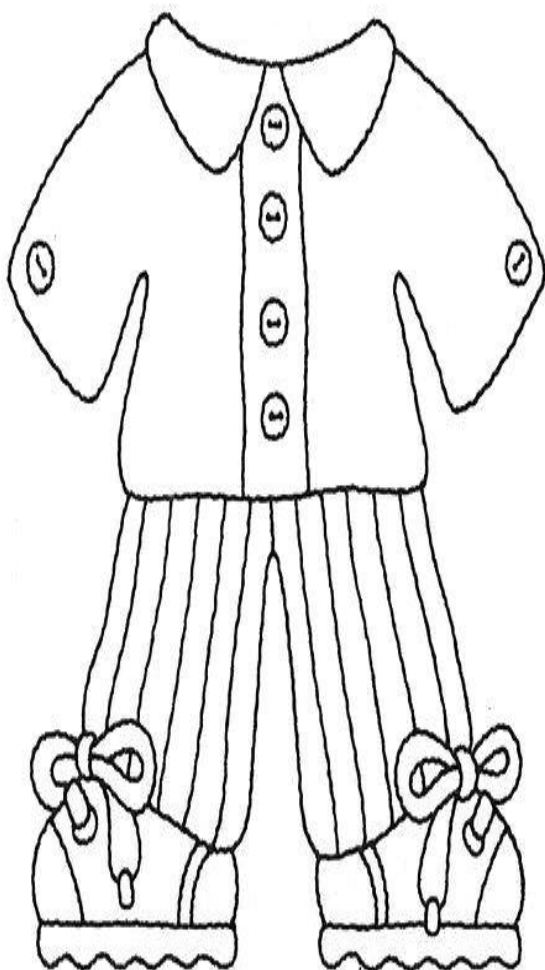

# EL JUEGO DE LAS DIFERENCIAS

DESCUBRE Y MARCA CON UNA CRUZ CADA DIFERENCIA QUE ENCUENTRES ENTRE ESTOS DOS DIBUJOS.

COLOREA UN CÍRCULO POR CADA DIFERENCIA ENCONTRADA.

